

**Wednesday 13 June 2012 – Morning**

**GCSE MATHEMATICS A**

**A503/02** Unit C (Higher Tier)

\* A 5 0 3 / 0 2 0 6 1 2 \*

Candidates answer on the Question Paper.

**OCR supplied materials:**  
None

**Other materials required:**

- Scientific or graphical calculator
- Geometrical instruments
- Tracing paper (optional)

**Duration: 2 hours**



Candidate forename		Candidate surname	
--------------------	--	-------------------	--

Centre number						Candidate number				
---------------	--	--	--	--	--	------------------	--	--	--	--

**INSTRUCTIONS TO CANDIDATES**

- Write your name, centre number and candidate number in the boxes above. Please write clearly and in capital letters.
- Use black ink. HB pencil may be used for graphs and diagrams only.
- Answer **all** the questions.
- Read each question carefully. Make sure you know what you have to do before starting your answer.
- Your answers should be supported with appropriate working. Marks may be given for a correct method even if the answer is incorrect.
- Write your answer to each question in the space provided. Additional paper may be used if necessary but you must clearly show your candidate number, centre number and question number(s).
- Do **not** write in the bar codes.

**INFORMATION FOR CANDIDATES**

- The number of marks is given in brackets [ ] at the end of each question or part question.
- Your Quality of Written Communication is assessed in questions marked with an asterisk (\*).
- Use the  $\pi$  button on your calculator or take  $\pi$  to be 3.142 unless the question says otherwise.
- The total number of marks for this paper is **100**.
- This document consists of **24** pages. Any blank pages are indicated.

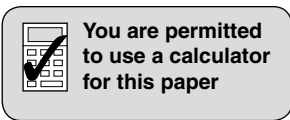

This paper has been pre modified for carrier language

## Formulae Sheet: Higher Tier

**Area of trapezium** =  $\frac{1}{2}(a + b)h$

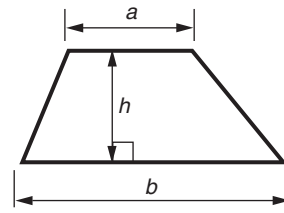

**Volume of prism** = (area of cross-section)  $\times$  length

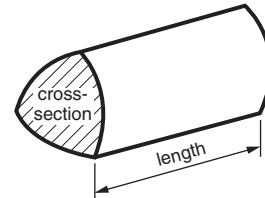

**In any triangle ABC**

**Sine rule**  $\frac{a}{\sin A} = \frac{b}{\sin B} = \frac{c}{\sin C}$

**Cosine rule**  $a^2 = b^2 + c^2 - 2bc \cos A$

**Area of triangle** =  $\frac{1}{2}ab \sin C$



**Volume of sphere** =  $\frac{4}{3}\pi r^3$

**Surface area of sphere** =  $4\pi r^2$



**Volume of cone** =  $\frac{1}{3}\pi r^2 h$

**Curved surface area of cone** =  $\pi r l$



**The Quadratic Equation**

The solutions of  $ax^2 + bx + c = 0$ ,  
where  $a \neq 0$ , are given by

$$x = \frac{-b \pm \sqrt{b^2 - 4ac}}{2a}$$

**PLEASE DO NOT WRITE ON THIS PAGE**

1 Complete the five missing amounts in this bill.

35 m <sup>2</sup> of carpet at £25.20 per m <sup>2</sup>	£_____
35 m <sup>2</sup> of underlay at £_____ per m <sup>2</sup>	£_____
Fixings	£ 13.35
Cost of all items	£ 1112.00
VAT (20% of the cost of all items)	£_____
TOTAL	£_____

[5]

2 This garden bench is made from three cuboids.

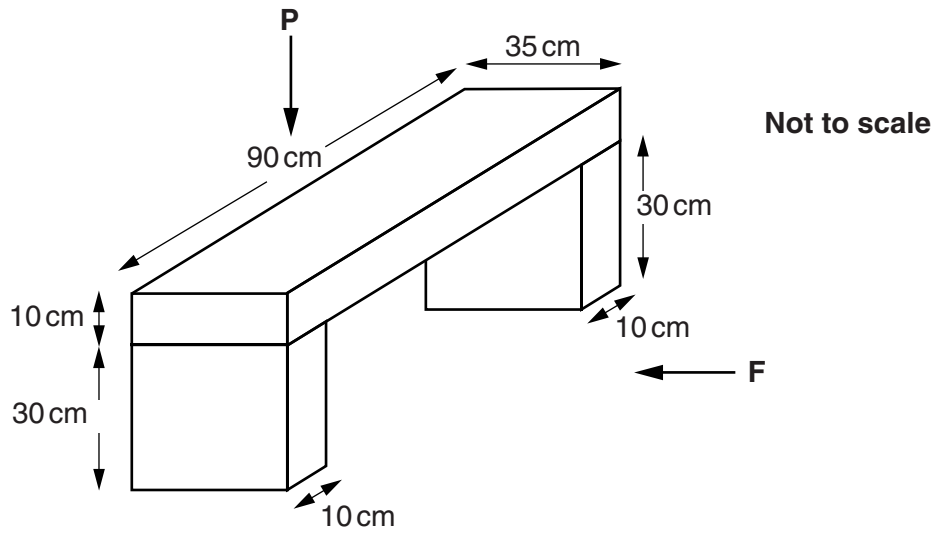

(a) On the grids, draw the front elevation (view from F) and the plan (view from P). Use a scale of 1 cm to represent 10 cm.

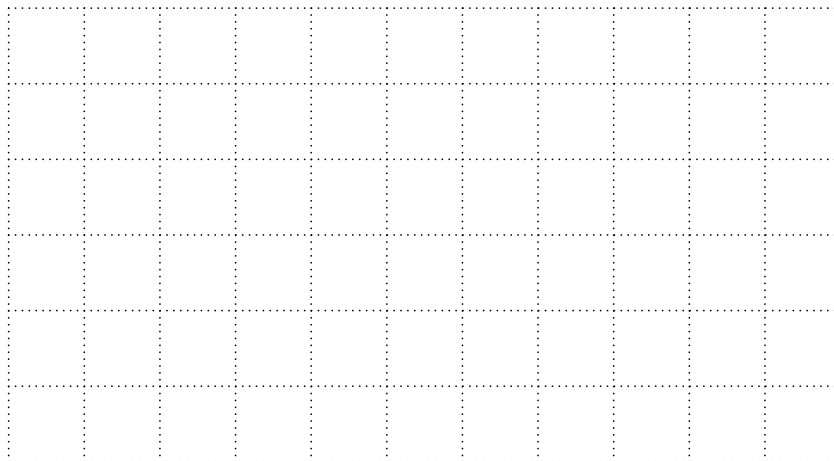

Front elevation

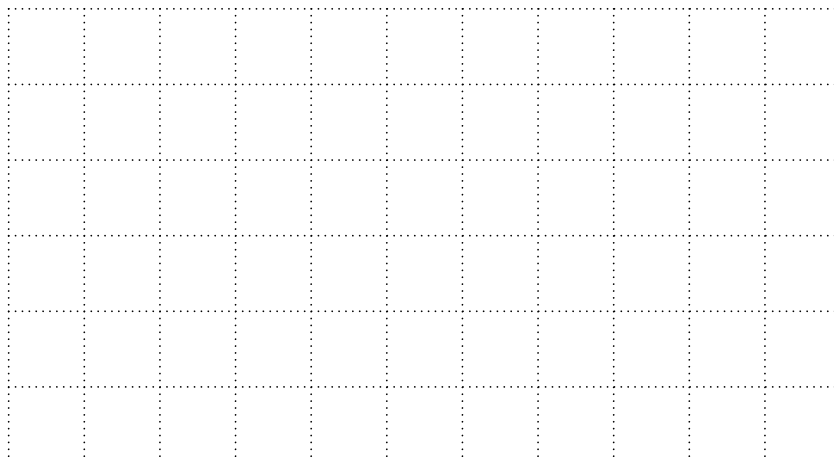

Plan

[4]

- (b) Work out the total volume of the garden bench.  
Give the units of your answer.

(b) \_\_\_\_\_ [4]

- (c) The weight of the bench is 75 kg, correct to the nearest kilogram.

What are the upper and lower bounds of this weight?

(c) Upper bound \_\_\_\_\_ kg

Lower bound \_\_\_\_\_ kg [2]

- 3\* Ken has £4000 to invest.  
He decides to invest it for 3 years at a rate of 5% per year.

How much more interest will he earn if he invests it at Compound Interest rather than Simple Interest?

£ \_\_\_\_\_ [5]

- 4 A box contains yellow, blue, red and green pencils.  
Josie takes a pencil at random.

The probability that she takes a yellow pencil is 0.2.  
The probability that she takes a blue pencil is 0.35.  
The probability that she takes a red pencil is 0.15.

- (a) (i) What is the probability that Josie will take a green pencil?

(a)(i) \_\_\_\_\_ [2]

- (ii) What is the probability that Josie will take a yellow **or** a blue pencil?

(ii) \_\_\_\_\_ [2]

- (b) Josie takes a pencil at random from the box, checks its colour and returns it to the box.  
She then takes another pencil at random.

What is the probability that the first pencil is red **and** the second pencil is red?

(b) \_\_\_\_\_ [2]

- (c) There are 8 yellow pencils in the box.

How many pencils are in the box altogether?

(c) \_\_\_\_\_ [3]

5 (a) Multiply out.

$$3(7x + 6)$$

(a) \_\_\_\_\_ [2]

(b) Multiply out and simplify fully.

$$6(y - 5) + 2(3 + 2y)$$

(b) \_\_\_\_\_ [3]

6 The equation  $x^3 - 6x = 4$  has a solution between 2 and 3.

Use trial and improvement to find this solution correct to one decimal place.  
Show all your trials and their outcomes.

\_\_\_\_\_ [4]



7 Anil is doing a traffic survey.

He is recording how much of the traffic approaching his town goes to the town centre and how much uses the ring road around the town.

Every Monday for three weeks, Anil stands at the junction of the road to the town centre and the ring road.

He counts the number of cars going in each of these directions.

Here are his results.

Direction	Number of cars		
Town centre	275	255	241
Ring road	174	195	170

(a) Explain why it is reasonable to estimate the probabilities of cars travelling in each of these directions from this survey.

\_\_\_\_\_ [1]

(b) Use the figures to estimate the probability that next Monday a randomly chosen car approaching the town will go to the town centre.

(b) \_\_\_\_\_ [3]

- 8 The diagram shows a triangular prism.  
 O is the origin, A is (6, 0, 0), E is (0, 5, 0) and D is (0, 0, 3).  
 All lengths are in centimetres.

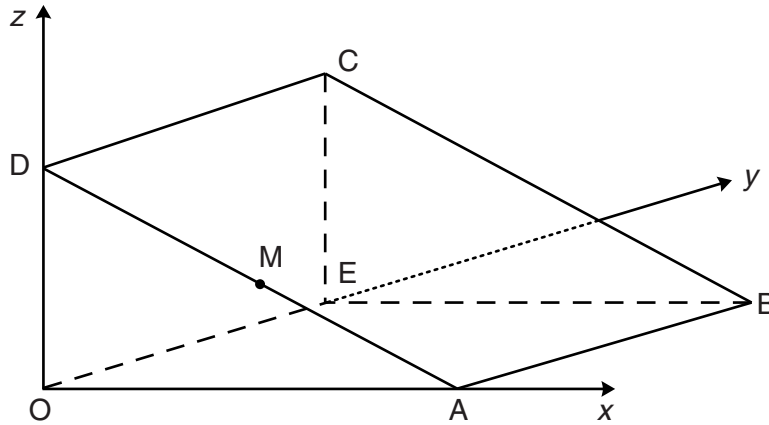

(a) Write down the coordinates of

(i) C,

(a)(i) ( \_\_\_\_\_ , \_\_\_\_\_ , \_\_\_\_\_ ) [1]

(ii) B,

(ii) ( \_\_\_\_\_ , \_\_\_\_\_ , \_\_\_\_\_ ) [1]

(iii) M, the midpoint of AD.

(iii) ( \_\_\_\_\_ , \_\_\_\_\_ , \_\_\_\_\_ ) [1]

(b) Work out the area of triangle OAD.

(b) \_\_\_\_\_ cm<sup>2</sup> [2]

(c) Work out the length BD.

(c) \_\_\_\_\_ cm [3]

- 9 (a) Write  $1.86 \times 10^5$  as an ordinary number.

(a) \_\_\_\_\_ [1]

- (b) This is a formula used in physics.

$$E = mc^2$$

Calculate  $E$  when  $m = 5 \times 10^{-4}$  and  $c = 3 \times 10^8$ .  
Give your answer in standard form.

(b) \_\_\_\_\_ [2]

- (c) Rearrange the formula

$$E = mc^2$$

to make  $c$  the subject.

(c) \_\_\_\_\_ [2]

- 10 The diagram shows the plan of a room.  
All lengths are in metres.

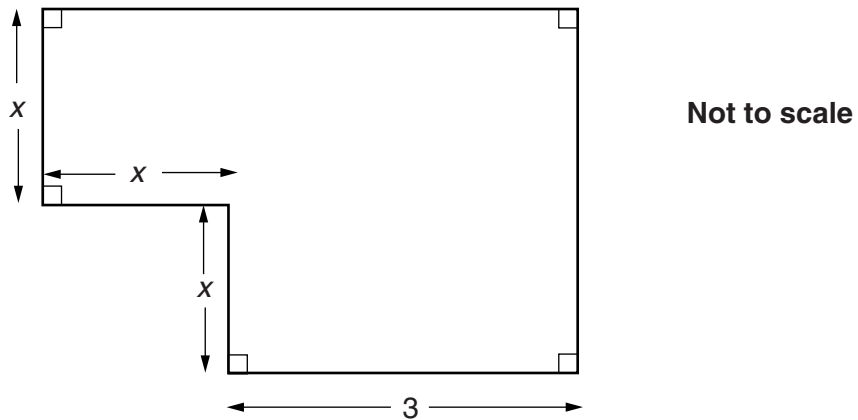

- (a) Show that the total area of the room,  $A \text{ m}^2$ , can be given by this formula.

$$A = x^2 + 6x$$

[2]

- (b) Complete the table for  $A = x^2 + 6x$ .

$x$	0	1	2	3	4	5
$A$	0		16	27	40	

[2]

(c) Draw the graph of  $A = x^2 + 6x$  for  $x$  from 0 to 5.

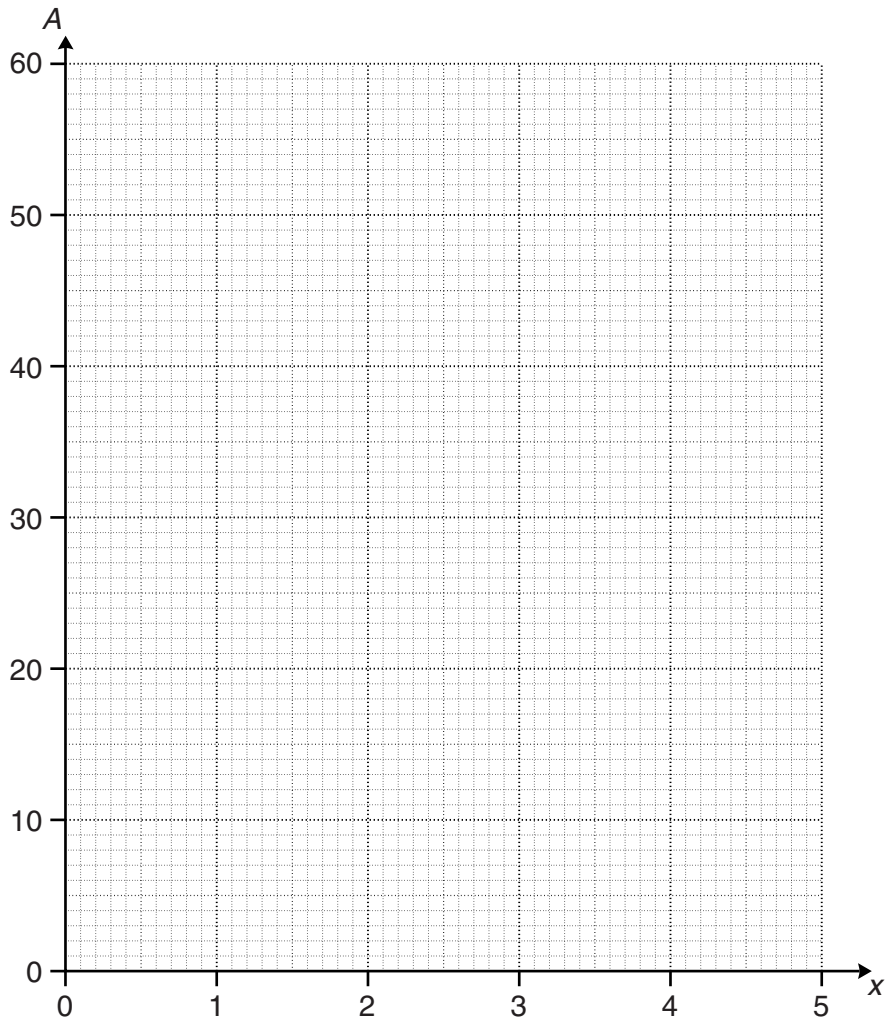

[2]

(d) The total area of the room is  $35 \text{ m}^2$ .

Use your graph to find the length  $x$ .

(d) \_\_\_\_\_ m [1]

11 (a) Solve this quadratic equation by factorisation.

$$x^2 - 7x + 10 = 0$$

(a) \_\_\_\_\_ [3]

(b) Solve algebraically these simultaneous equations.

$$\begin{aligned}4x + 3y &= 6 \\ y &= 13 - 5x\end{aligned}$$

(b)  $x =$  \_\_\_\_\_

$y =$  \_\_\_\_\_ [4]

12 These diagrams are mathematically similar.

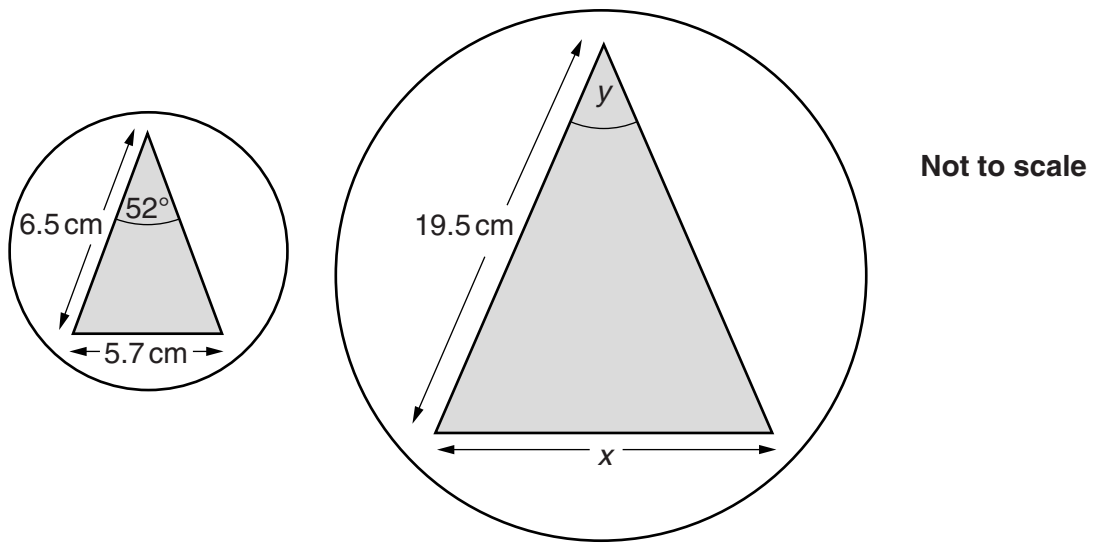

(a) Calculate the length  $x$ .

(a) \_\_\_\_\_ cm [3]

(b) What is the size of angle  $y$ ?

(b) \_\_\_\_\_ ° [1]

(c) The area of the smaller circle is  $51 \text{ cm}^2$ .

Calculate the area of the larger circle.

(c) \_\_\_\_\_  $\text{cm}^2$  [2]

13 (a) Work out.

$$(\sqrt{3})^2$$

(a) \_\_\_\_\_ [1]

(b) Multiply out and simplify fully.

$$(4 + 5\sqrt{3})(2 + 7\sqrt{3})$$

You must show your working.

(b) \_\_\_\_\_ [3]



14 The diagram shows two fair spinners.

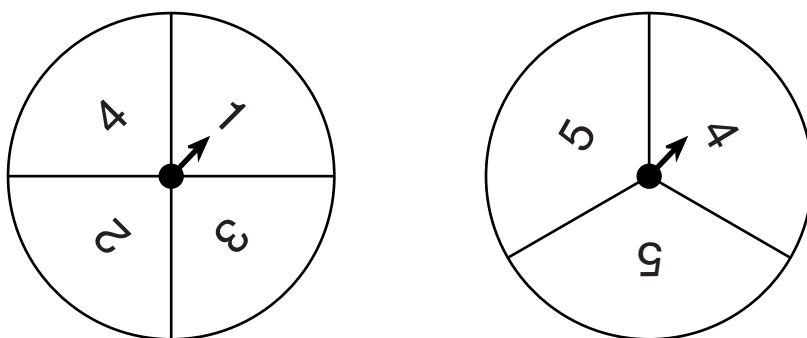

Both spinners are spun and the scores are added together.

Work out the probability that the total of the two scores is 8 or more.  
Show your working clearly.

---

[5]

- 15 TP is a tower on horizontal ground, ABP.  
Two straight cables, AT and BT, connect the top, T, of the tower to the ground.

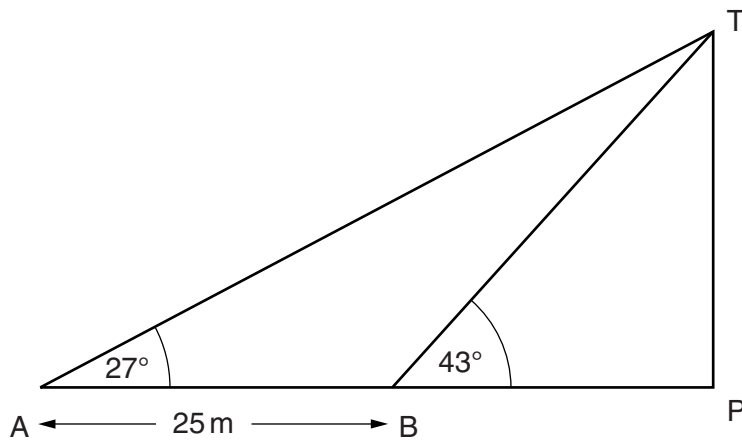

AT and BT make angles with the ground of  $27^\circ$  and  $43^\circ$  respectively.  
B is 25m closer to the foot of the tower, P, than A.

Work out the length of the cable AT.

\_\_\_\_\_ m [4]

16 Peter is using the quadratic formula to solve an equation of the form

$$ax^2 + bx + c = 0.$$

After substituting values and some calculation he arrives at this stage in his working.

$$x = \frac{-5 \pm \sqrt{73}}{4}$$

Work out possible values for  $a$ ,  $b$  and  $c$ .

$$a = \underline{\hspace{10cm}}$$

$$b = \underline{\hspace{10cm}}$$

$$c = \underline{\hspace{10cm}} \quad [4]$$

17 The diagram shows a tent.

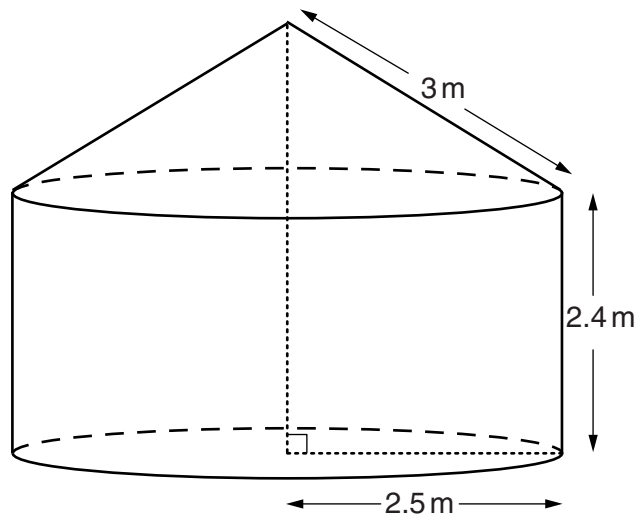

The base of the tent is a circle of radius 2.5 m.  
The walls are vertical and are 2.4 m high.  
The roof of the tent is a cone of slant height 3 m.  
The material to make the tent costs £8.99 per square metre.

Work out the total cost of the material needed to make the walls and roof of the tent.

£ \_\_\_\_\_ [5]

18 Write as a single algebraic fraction.

$$\frac{x+5}{x-2} - \frac{x}{x-3}$$

\_\_\_\_\_ [3]

**BLANK PAGE**

**PLEASE DO NOT WRITE ON THIS PAGE**

**BLANK PAGE**

**PLEASE DO NOT WRITE ON THIS PAGE**

**PLEASE DO NOT WRITE ON THIS PAGE**



**Copyright Information**

OCR is committed to seeking permission to reproduce all third-party content that it uses in its assessment materials. OCR has attempted to identify and contact all copyright holders whose work is used in this paper. To avoid the issue of disclosure of answer-related information to candidates, all copyright acknowledgements are reproduced in the OCR Copyright Acknowledgements Booklet. This is produced for each series of examinations and is freely available to download from our public website ([www.ocr.org.uk](http://www.ocr.org.uk)) after the live examination series.

If OCR has unwittingly failed to correctly acknowledge or clear any third-party content in this assessment material, OCR will be happy to correct its mistake at the earliest possible opportunity.

For queries or further information please contact the Copyright Team, First Floor, 9 Hills Road, Cambridge CB2 1GE.

OCR is part of the Cambridge Assessment Group; Cambridge Assessment is the brand name of University of Cambridge Local Examinations Syndicate (UCLES), which is itself a department of the University of Cambridge.