



OXFORD CAMBRIDGE AND RSA EXAMINATIONS

**LEVEL 3 CERTIFICATE OF PROFESSIONAL
COMPETENCE FOR TRANSPORT MANAGERS
(PASSENGER TRANSPORT)**

05678

**UNIT P2 CERTIFICATE OF PROFESSIONAL COMPETENCE
(PASSENGER TRANSPORT) CASE STUDY**

FRIDAY 7 MARCH 2014 1.00 PM – 3.15 PM TIME: 2 HOURS 15 MINUTES

CASE STUDY

Background

Assessment Bus and Coach (ABC) has operated as a partnership from its depot in Lincoln for 15 years. ABC holds a Standard International Operator Licence. You are the nominated Transport Manager.

The business has grown significantly in recent months. The partners are now considering changing the status of ABC to a Limited Liability Partnership or to a Limited Company.

Operations

Current work includes private hire, school and works contracts, a programme of day tours and some local bus services.

ABC's current fleet comprises:-

- 2 x 49-seat tour coaches
- 8 x 53-seat standard coaches
- 2 x 30-seat standard coaches
- 3 x 20-seat standard coaches
- 4 x 41-seat buses

All maintenance is currently done 'in-house'.

Financial and Operating Information

Costs	20-seat coach	30-seat coach	53-seat coach	49-seat coach	41-seat bus
Standing costs and overheads per day (£)	80	90	170	180	90
Maintenance cost per km (£)	0.35	0.45	0.50	0.50	0.50
Tyre cost per km (£)	0.03	0.04	0.05	0.06	0.04
Driver wage per day (£)	100	100	100	100	100
Driver overnight allowance per night (£)	25	25	25	25	N/A
Fuel consumption (km/l)	8	6	4	4	5

Fig. 1

All fuel is purchased at £1.20 per litre.

20% mark-up is applied to all quotations and tenders.

Company Policies and Procedures

Drivers are always scheduled for 30 minutes at the beginning and 30 minutes at the end of every duty, to complete vehicle checks and paperwork.

All ABC's drivers have signed a workforce agreement that allows them to exceed the 10-hour night work limit.

All international journeys operate with the same crew on outbound and inbound journeys.

New business opportunity

ABC has received an expression of interest from OCR Coach Holidays Ltd (OCR). OCR has identified ABC's site as an ideal location as a transfer hub.

OCR has indicated that it may also want to hire coaches from ABC for its holiday programme including feeder services and its ski shuttle service.

OCR has outlined its requirements in an email to ABC, extracts from which are shown in Figs. 2, 3 and 4:

Rhine Valley Holiday information – 10 days

Day	Itinerary	Total Mileage (km)
1	Lincoln Depot to Dover/Calais (overnight in Calais)	360
2	Calais - Cologne	410
3	Cologne – Koblenz and return	215
4	Cologne – Trier and return	325
5	Free Day in Cologne (coach not required)	0
6	(pm) Cologne City Tour (round trip)	80
7	Cologne – Bonn and return	80
8	Cologne – Liege and return	250
9	Cologne – Calais (overnight in Calais)	410
10	Calais to Dover then Lincoln Depot	360

Fig. 2

Rhine Valley Holiday Feeder Services information.

Local pick-ups in the Lincoln area will be needed.

Passenger pick-up requirements are shown in Fig. 3 and Fig. 4.

Pick-up point	Number of passengers at pick-up point
A	3
B	8
C	11
D	5
E	3
F	6
G	4
H	5
J	15

Fig. 3

Map of feeder pick-up area (not to scale)

The map in Fig. 4 shows the pick-up points and the road mileage between those points in kilometres.

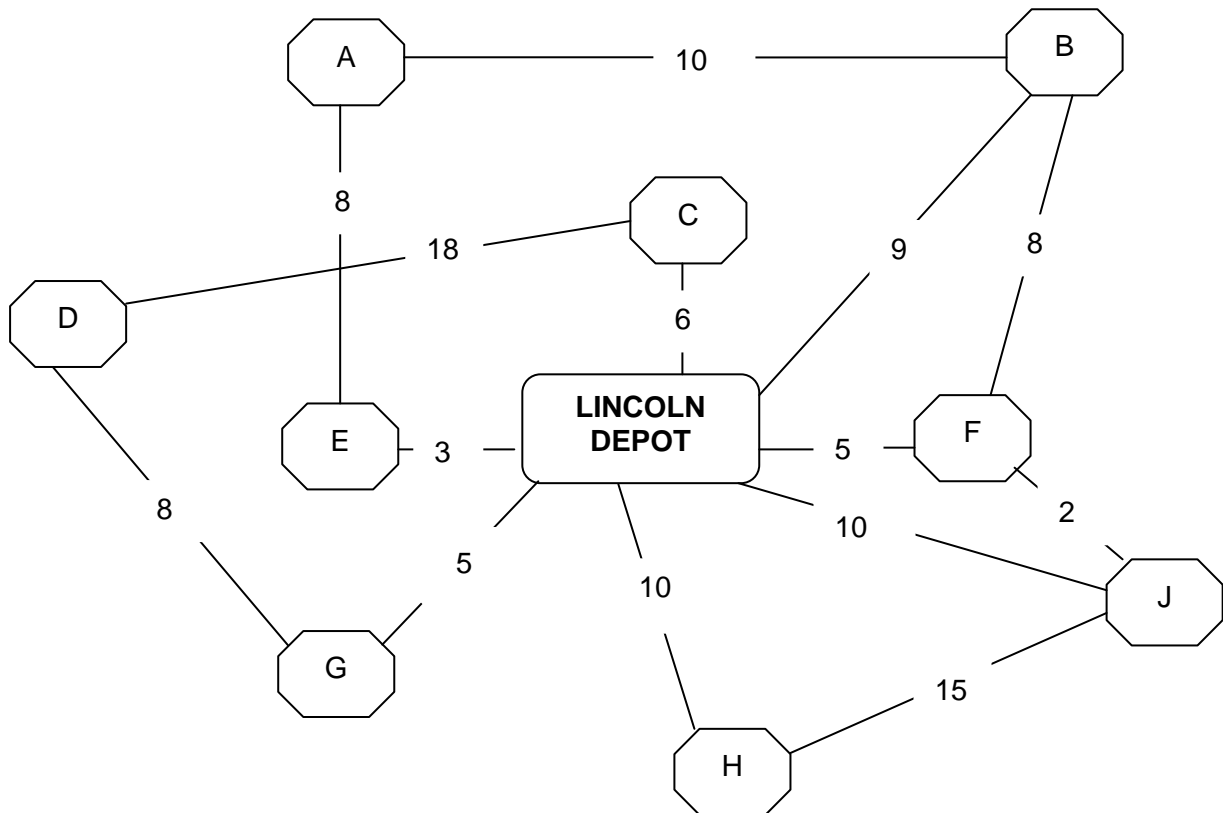

Fig. 4

Ski Shuttle Service information.

Depart Lincoln Depot – Friday.

Destination – Annecy (France) to arrive no later than midday Saturday (local time).

One (ONLY) break of no more than 30 minutes must be made en route between Calais and Annecy, at the service area which is 405 km from Calais.

Distances – Lincoln Depot to Dover - 360 km

Calais to Annecy – 810 km

OCR has negotiated a contract rate with the Cross Channel Ferry Company which specifies using the 23:30hrs Dover to Calais crossing for the outbound journey.

Embarkation and disembarkation each take 15 minutes (counted as driving time)

Check in at Dover takes 15 minutes.

Dover/Calais Ferry crossing time is 90 minutes.

Loading/unloading at Lincoln and at Annecy is handled by OCR staff, while the vehicle checks and paperwork are completed.

Further information

OCR has also indicated that it may wish to base some of its own coaches at ABC's depot, and contract ABC to provide maintenance and inspection services.

THIS PAGE HAS BEEN LEFT INTENTIONALLY BLANK

THIS PAGE HAS BEEN LEFT INTENTIONALLY BLANK

Oxford Cambridge and RSA Examinations is a Company Limited by Guarantee
Registered in England
Registered Office: 1 Hills Road, Cambridge, CB1 2EU
Registered Company Number: 3484466
OCR is an exempt Charity

E102 1403