

Live Assessment

Assessment Material

OCR Level 1/2 Cambridge National Award in Engineering Manufacture
OCR Level 1/2 Cambridge National Certificate in Engineering Manufacture

R110: Preparing and planning for manufacture

Please note:

This OCR model assignment is to be used to provide evidence for the unit identified above. Alternatively, centres may 'tailor' or modify the assignment within permitted parameters (see Information for Teachers). It is the centre's responsibility to ensure that any modifications made to this assignment allow learners to show that they can meet all of the learning outcomes and provide sufficient opportunity for learners to demonstrate achievement across the full range of marks.

INSTRUCTIONS TO TEACHERS

The OCR administrative codes associated with this unit are:

- unit entry code R110
- certification codes Award J831 / Certificate J841

The accreditation numbers associated with this unit are:

- unit reference number A/505/3539
- qualification reference(s) Award [601/1410/1] / Certificate [601/1411/3]
- **Duration: Approximately 10-12 hours**

ALL OF THIS MATERIAL MAY BE PHOTOCOPIED. Any photocopying will be done under the terms of the Copyright Designs and Patents Act 1988 solely for the purposes of assessment.

Contents

	Page Number(s)
INFORMATION FOR LEARNERS	3
Scenario for the assignment	4
This section contains the assignment background which learners will need to be familiar with in order to complete the tasks.	
Your Tasks	5
This section contains all the tasks learners must complete before work can be submitted for assessment.	
INFORMATION FOR TEACHERS	7
Guidance on using this assignment	8 - 12
This section provides guidance to centre staff on the preparation and completion of the assignment.	

Live Assessment: Information for Learners

OCR Level 1/2 Cambridge National Award in Engineering Manufacture
OCR Level 1/2 Cambridge National Certificate in Engineering Manufacture

R110: Preparing and planning for manufacture

Scenario for the Assignment

A new F1 in schools wheel is to be manufactured. A pre-production version of the wheel is required in order to test the design. The wheel will be manufactured using conventional (non-computer numerical control (CNC)) methods. The component drawing for the wheel is shown below:

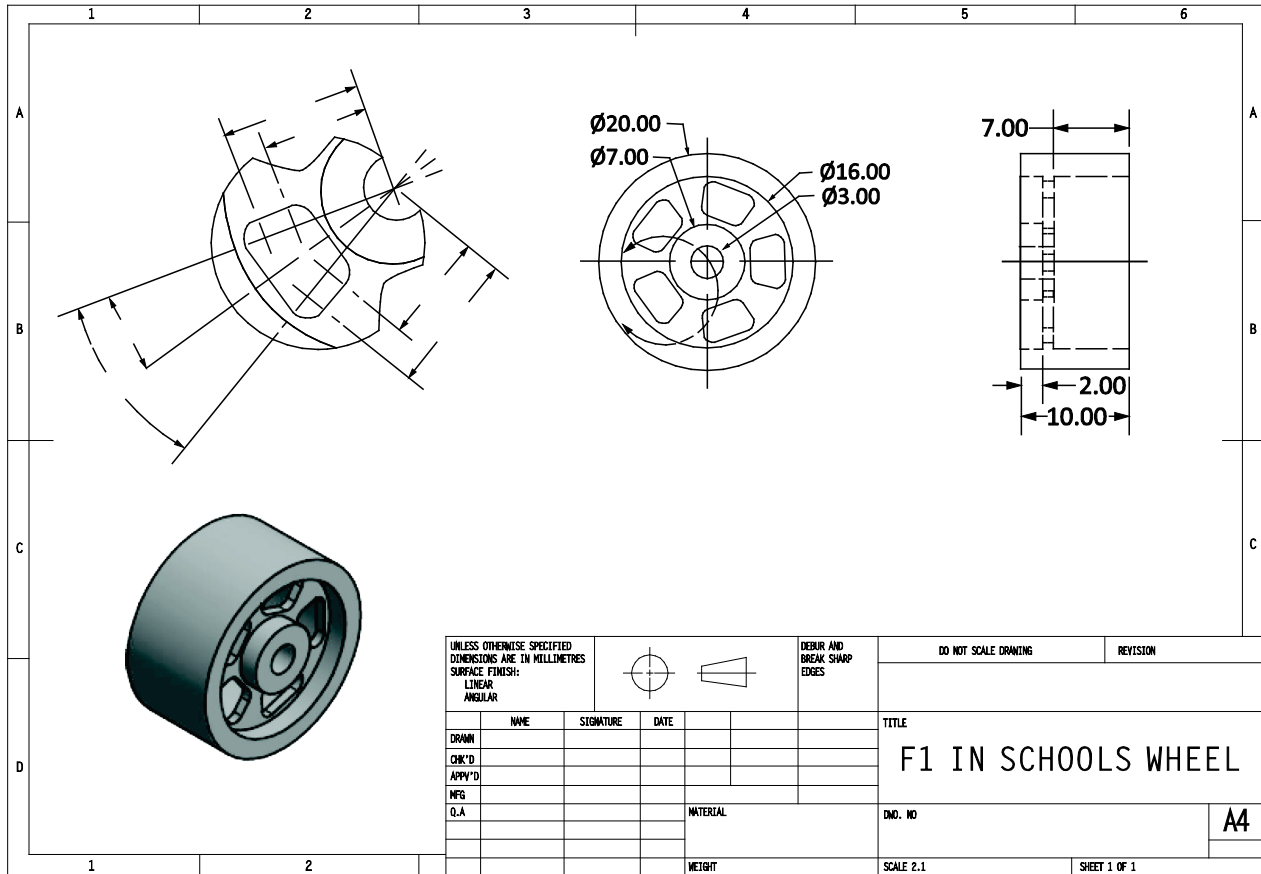

Read through all of the tasks carefully, so that you know what you will need to do to complete this assignment.

Your Tasks

Task 1: Production planning for a pre-production product

Learning Outcome 1, Be able to plan for the making of a pre-production product, is assessed in this task.

Interpret the 2D and 3D engineering drawings provided.

You will need to produce a detailed production plan for the manufacture of a pre-production wheel.

Task 2: Select and use production processes, tools and equipment safely to make a pre-production product

Learning Outcome 2, Be able to use processes, tools and equipment safely to make a pre-production product, is assessed in this task.

Working from your production plan and the engineering drawings provided, you are to manufacture the wheel using appropriate tools and equipment.

On completion of manufacture you should undertake appropriate quality control checks, drawing conclusions on the quality of the finished pre-production product.

You will need to produce a:

- conventionally (non-CNC) manufactured pre-production product
- review of the quality of the pre-production product.

Task 3: Modify production plans for different scales of production

Learning Outcome 3, Be able to modify a production plan for different scales of production, is assessed in this task.

The manufacturer has reviewed your wheel and has given approval for production. The next production run will be for a quantity of 1000 wheels. You need to consider the suggested scale of manufacture and the impact on the planning and processes used for manufacture.

You will need to produce a modified plan suitable for the specified quantity production of the product.

Information for Teachers

OCR Level 1/2 Cambridge National Award in Engineering Manufacture
OCR Level 1/2 Cambridge National Certificate in Engineering Manufacture

R110: Preparing and planning for manufacture

Guidance on using this assignment

1 General guidance

- 1.1 OCR assignments are available to download free of charge from our website:
www.ocr.org.uk
- 1.2 OCR assignments are intended to be used for summative assessment of learners. The OCR specification gives more information on the arrangements for assessing internally assessed units.
- 1.3 This assignment has been designed to meet the full assessment requirements of the unit. Learners will need to take part in a planned learning programme that covers the underpinning knowledge, understanding and skills of the unit.

2 Before carrying out the assignment

- 2.1 Learners should be provided with a copy of the *Information for Learners* section of this assignment.
- 2.2 Learners will not need to carry out any preparations prior to undertaking the assessment tasks, such as collating resources to use in the assessment
- 2.3 We have estimated that it will take approximately 10-12 hours to complete all tasks. Learners would need approximately 3 hours to complete Task 1 and approximately 5-8 hours to complete Task 2 and 2 hours to complete Task 3. These timings are for guidance only but should be used by the teacher to give learners an indication of how long to spend on each task. Centres can decide how the time can be allocated between each part or individual task. Centres are also permitted to spread the tasks across several sessions and therefore it is permissible for evidence to be produced over several sessions.

3 When completing the assignment and producing evidence

- 3.1 Each learner must produce individual and authentic evidence for each task within the assignment.
- 3.2 Centre staff may give support and guidance to learners. This support and guidance should focus on checking that learners understand what is expected of them and giving general feedback that enables the learner to take the initiative in making improvements, rather than detailing what amendments should be made. It is not acceptable for teachers/deliverers to provide answers, to work through answers in detail or to detail specifically what amendments should be made.
- 3.3 Learners may use information from any relevant source to help them with producing evidence for the tasks.
- 3.4 Learners must be guided on the use of information from other sources to ensure that confidentiality is maintained at all times.

- 3.5 Usually, the type of evidence required may be modified, with the exception of certain types of evidence listed below under '*Permitted changes*'. It is important to note that it is possible to generate the evidence in a variety of formats. Centres must advise learners as to the most appropriate format of evidence. The nature of this assessment means that learners are free to use the format that they feel is most appropriate for the purpose and target audience for each individual task (see Section 6).

4 Presentation of work for marking and moderation

- 4.1 Centres wishing to produce digital evidence in the form of an e-portfolio should refer to the appendix in the specification on guidance for the production of electronic assessment.
- 4.2 Centres may wish to discourage learners from excessive use of plastic wallets for presentation of their evidence as this may hinder the assessment process. Instead centres may wish to encourage learners to present their work so that it is easily accessible, e.g. spiral bound, stapled booklet, treasury tag.
- 4.3 All work must be marked against the marking criteria for the unit. Marks are allocated to learning outcomes rather than tasks. Please see Appendix B Marking criteria for centre assessment and Section 4 The centre assessed units in the specification for this qualification for more information on marking, moderation and submission of work.

5 Scope of permitted model assignment modification

The model assignment is self-contained in its present form. The set of tasks form a coherent whole addressing all the learning outcomes and allowing access to the full range of marks.

You must not change the following:

- the learning outcomes
- the marking criteria
- the requirements for supervision and authentication as described in the specification (Section 4 *The centre assessed units*)
- the maximum duration for completion of the assignment.

Permitted changes:

The model assignment can be modified in terms of the areas described below but centres must be sure that learners still have the opportunity to cover all of the learning outcomes and to access the full range of marks:

- the scenario, which can be contextualised or amended to suit local needs
- each specific task may be appropriately contextualised to match with any permitted changes you have made to the scenario.

Should the centre change the context of the assignment they must make sure that the product to be designed and prototyped is of equal complexity to that given in this model assignment.

OCR has ensured that in the language used and the tasks and scenario provided we have avoided discrimination, bias and stereotyping and support equality and diversity. In the development of qualifications and assessments we use the guidance given in the Ofqual publication *Fair access by design*, notably this includes:

- using language and layout in assessment materials that does not present barriers to learners
- using stimulus and source materials in assessment materials (where appropriate) that do not present barriers to learners.

If centres wish to modify the model assignment we strongly advise that staff responsible for modifying the model assignment and the quality assurance of it refer to the publication *Fair access by design*.

If modifications are made to the model assignment, whether to just the scenario or to both the scenario and individual tasks, it is up to the centre to ensure that all learning outcomes can still be met and that learners can access the full range of marks.

6 Specific guidance on the task

ICT facilities including digital photography and/or video will be required to produce the portfolio of evidence required for assessment.

A portfolio of evidence should be produced for assessment. This may be presented in the form of an electronic portfolio containing both written and video evidence showing all processes and procedures involved in the manufacture of the prototype product with written evidence to support production planning and quality control tasks.

Task 1

Learners should use the supplied engineering drawing. They should independently plan the safe production of the component. Correct interpretation of engineering drawings is to be evidenced in the production plan and the product made.

Task 2

Supervision of learners should be undertaken to ensure that safe working practices are followed at all times. The level of supervision required should be reflected in assessment as per the marking criteria for the unit.

This task should be completed using manual machining operations. CNC equipment should not be used.

Learners will require access to manufacturing facilities such as a centre lathe or milling machine. Appropriate risk assessment should be undertaken and learners should be supplied with personal protective equipment (PPE).

Learners will be assessed on their preparation/setting of machines and equipment, their application of the making plan, and the safe use of machines/equipment in the making of the product. A combination of hand and machine processes should be required in the making of the product, and the use of a minimum of three different processes must be demonstrated.

Evidence of the setting and safe use of machines/equipment should be provided in the portfolio by videos and/or digital photographs, which may be supported by signed witness statements.

Task 3

Learners will need to present a justified review of the plan after completion of the making, suggesting any improvements/changes that could be made to any elements of the overall plan.

Learners should then produce a modified plan that would be suitable for use when making the product in larger quantities.

Total marks for assignment: 60

Witness Statement – Task 1 and 2

LEARNER NAME	
Date	
Unit	R110 – Preparing and planning for Manufacture
LO1 and LO2	Be able to: <ul style="list-style-type: none">• plan for the making of a pre-production product• use processes, tools and equipment safely to make a pre-production product.

Independent working to manufacture, whilst following appropriate safety precautions

Witness observations	
-----------------------------	--

Name of witness: _____

Relationship to learner: _____

Assessor comments: How the observations demonstrate achievement against the marking criteria

--

RECORD OF QUESTIONS/ANSWERS (if applicable)

ASSESSOR QUESTION 1	
LEARNER RESPONSE 1	
ASSESSOR QUESTION 2	
LEARNER RESPONSE 2	
ASSESSOR QUESTION 3	
LEARNER RESPONSE 3	

ASSESSOR SIGNATURE:		DATE:	
----------------------------	--	--------------	--

LEARNER SIGNATURE:		DATE:	
---------------------------	--	--------------	--