

OCR

Oxford Cambridge and RSA

Monday 6 June 2016 – Afternoon

GCSE ENGINEERING

A624/02 Impact of Modern Technologies on Engineering

Candidates answer on the Question Paper.

OCR supplied materials:

None

Other materials required:

None

Duration: 1 hour



Candidate forename		Candidate surname	
-----------------------	--	----------------------	--

Centre number						Candidate number				
---------------	--	--	--	--	--	------------------	--	--	--	--

INSTRUCTIONS TO CANDIDATES

- Write your name, centre number and candidate number in the boxes above. Please write clearly and in capital letters.
- Use black ink. HB pencil may be used for graphs and diagrams only.
- Answer **all** the questions.
- Read each question carefully. Make sure you know what you have to do before starting your answer.
- Write your answer to each question in the space provided. Additional paper may be used if necessary but you must clearly show your candidate number, centre number and question number(s).
- Do **not** write in the bar codes.

INFORMATION FOR CANDIDATES

- The number of marks is given in brackets [] at the end of each question or part question.
- The total number of marks for this paper is **60**.
- Your Quality of Written Communication will be assessed in questions marked with an asterisk (*).
- This document consists of **12** pages. Any blank pages are indicated.

Answer all questions.

1 Engineering sectors produce different products.

(a) Complete the table below by giving **two** examples of products made in each of the engineering sectors given.

Engineering sector	Product
Electrical and Electronics	1 2
Rail and Marine	1 2
Aerospace	1 2

[6]

(b) Name **two** engineering sectors not shown above.

- 1
- 2

[2]

2 The list below shows a number of engineering materials.

- | | |
|------------------|--------------------------|
| Brass | GRP |
| Copper | HDPE |
| Concrete | High carbon steel |
| Duralumin | PVC |

(a) Select a suitable material from the list to complete the following statements:

- (i) is an alloy [1]
- (ii) is a polymer [1]
- (iii) is a non-ferrous metal [1]
- (iv) is a composite [1]

(b) (i) Choose **one** material from the list and give **one** product made using that material.

Material
Product [1]

(ii) Give **two** reasons why the material you chose in part (b)(i) is suitable for the product given.

1
2 [2]

(c) Give **three** factors, other than cost, that should be considered when selecting materials for engineered products.

1
2
3 [3]

3 Explain how modern technologies might be used during the following stages in the manufacture of an engineered product.

(i) Packaging and dispatch

.....
.....
.....
.....
.....
..... [3]

(ii) Processing and production

.....
.....
.....
.....
.....
..... [3]

4 Fig. 1 shows a number of engineering components.

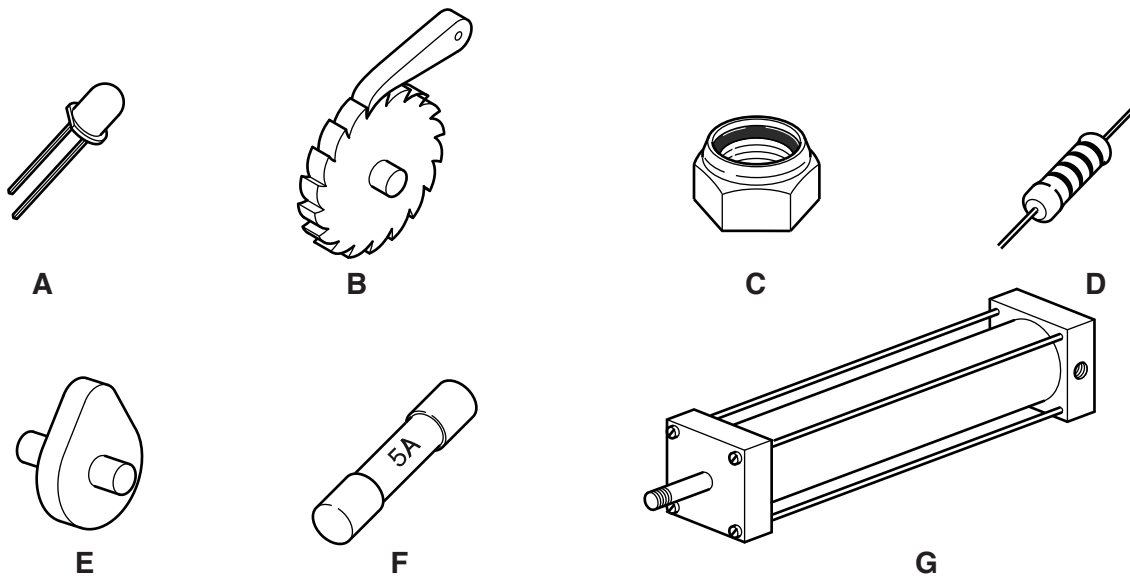

Fig. 1

(a) Choose **three** components from Fig. 1.

Complete the table below by giving the name of each component you have chosen and an example of its use.

One has been done for you.

Component	Name	Example of use
A	LED	used in torches

[6]

- (b) Show which type of engineering component a three-port valve is, by placing a tick (✓) in the correct box below.

Mechanical	Electrical	Electronic	Pneumatic

[1]

5 The list below gives different types of engineering processes.

- Material removal**
- Shaping and manipulation**
- Joining and assembly**
- Heat and chemical treatment**
- Surface finishing**

(a) Complete the table by giving **one** example of each type of engineering process. One has been done for you.

Type of engineering process	Example
Material removal	<i>Drilling</i>
Shaping and manipulation	
Joining and assembly	
Heat and chemical treatment	
Surface finishing	

[4]

(b) Describe how modern technologies might be used in a:

1 Joining and assembly process

.....

.....

.....

..... [2]

2 Surface finishing process

.....

.....

.....

..... [2]

6 The chart below shows the energy used at stages in the life of two different products.

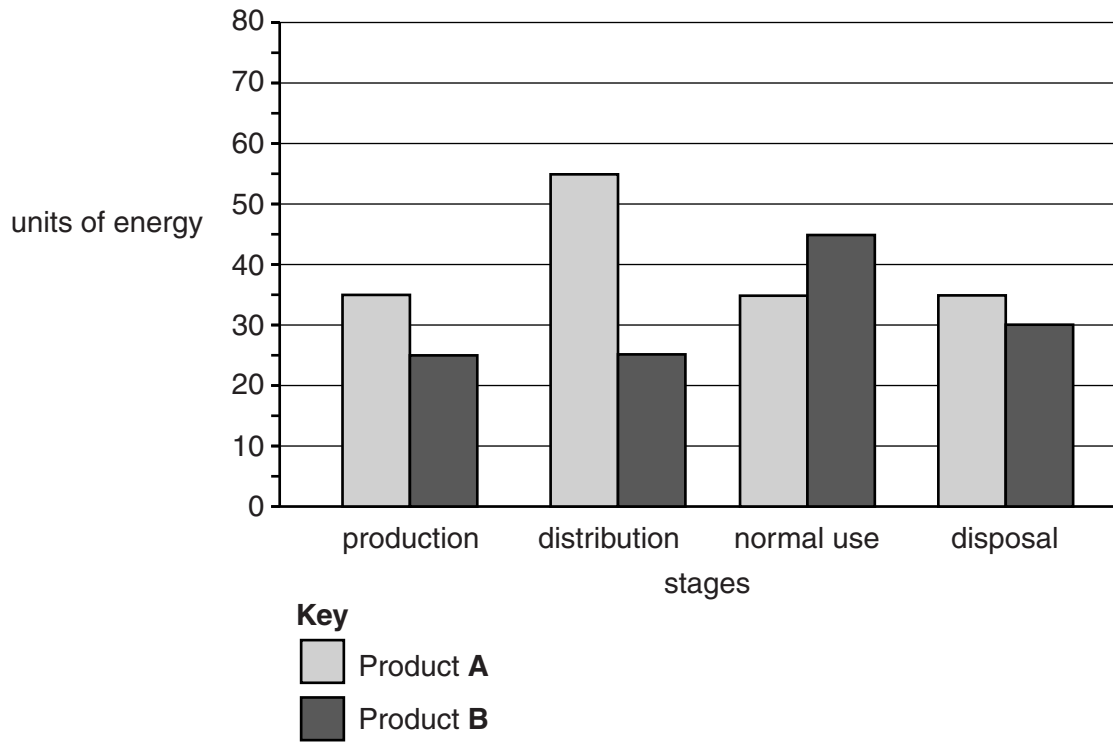

(a) State which of the products uses the most energy overall.

..... [1]

(b) Explain **two** possible reasons why Product A uses more energy in distribution than Product B.

1

.....

.....

..... [2]

2

.....

.....

..... [2]

(c) (i) Name **one** renewable energy source.

..... [1]

(ii) Explain the benefit of using a renewable energy source.

.....
..... [2]

7 (a) Describe **two** ways in which the use of modern technologies might benefit the environment.

1
.....
.....
..... [2]

2
.....
.....
..... [2]

(b) Explain, using **one** example, how 'design for ease of disassembly' can benefit the environment.

.....
.....
.....
.....
..... [3]

11
BLANK PAGE

PLEASE DO NOT WRITE ON THIS PAGE

PLEASE DO NOT WRITE ON THIS PAGE

OCR
Oxford Cambridge and RSA

Copyright Information

OCR is committed to seeking permission to reproduce all third-party content that it uses in its assessment materials. OCR has attempted to identify and contact all copyright holders whose work is used in this paper. To avoid the issue of disclosure of answer-related information to candidates, all copyright acknowledgements are reproduced in the OCR Copyright Acknowledgements Booklet. This is produced for each series of examinations and is freely available to download from our public website (www.ocr.org.uk) after the live examination series. If OCR has unwittingly failed to correctly acknowledge or clear any third-party content in this assessment material, OCR will be happy to correct its mistake at the earliest possible opportunity.

For queries or further information please contact the Copyright Team, First Floor, 9 Hills Road, Cambridge CB2 1GE.

OCR is part of the Cambridge Assessment Group; Cambridge Assessment is the brand name of University of Cambridge Local Examinations Syndicate (UCLES), which is itself a department of the University of Cambridge.