

Cambridge National

Engineering

Unit **R113**: Electronic principles

Level 1/2 Cambridge National Award/Certificate in Systems Control in
Engineering

Mark Scheme for June 2016

OCR (Oxford Cambridge and RSA) is a leading UK awarding body, providing a wide range of qualifications to meet the needs of candidates of all ages and abilities. OCR qualifications include AS/A Levels, Diplomas, GCSEs, Cambridge Nationals, Cambridge Technicals, Functional Skills, Key Skills, Entry Level qualifications, NVQs and vocational qualifications in areas such as IT, business, languages, teaching/training, administration and secretarial skills.

It is also responsible for developing new specifications to meet national requirements and the needs of students and teachers. OCR is a not-for-profit organisation; any surplus made is invested back into the establishment to help towards the development of qualifications and support, which keep pace with the changing needs of today's society.

This mark scheme is published as an aid to teachers and students, to indicate the requirements of the examination. It shows the basis on which marks were awarded by examiners. It does not indicate the details of the discussions which took place at an examiners' meeting before marking commenced.

All examiners are instructed that alternative correct answers and unexpected approaches in candidates' scripts must be given marks that fairly reflect the relevant knowledge and skills demonstrated.

Mark schemes should be read in conjunction with the published question papers and the report on the examination.

OCR will not enter into any discussion or correspondence in connection with this mark scheme.

© OCR 2016

Question		Answer	Mark	Guidance
1	(a)	<p>The correct order is</p> <ul style="list-style-type: none"> • Battery • Ammeter • Fuse • Generator or Galvanometer 	4	<p>Award one mark for each correct component.</p> <p>Do not accept cell instead of battery.</p>
	(b)	<p>Digit 1 and Digit 2: Red and Yellow Multiplier and Tolerance: Orange and Gold</p>	2	<p>Award one mark for Red and Yellow.</p> <p>Award one mark for Orange and Gold.</p>
	(c)	<p>Total resistance = $10 + 6.8 + 8.2 = 25\Omega$</p>	1	<p>Award one mark for 25Ω or 25 with or without working..</p>
	(d)	<p>$V_o = (R_2 \times V_i) / R_T$</p> <p>$R_T = R_1 + R_2 = 1 + 2 = 3k\Omega$</p> <p>$V_o = (1 \times 6) / 3$ $= 2 V$</p>	3	<p>Award one mark for $V_o = (R_2 \times V_i) / R_T$.</p> <p>or $V_o = V_i \times R_2 / R_1 + R_2$</p> <p>Award one mark for</p> <p>$R_T = R_1 + R_2 = 1 + 2 = 3k\Omega$.</p> <p>Award one mark for</p> <p>$V_o = (1 \times 6) / 3$ $= 2 V$</p> <p>Award three marks for correct answer 2 or 2V without working.</p>

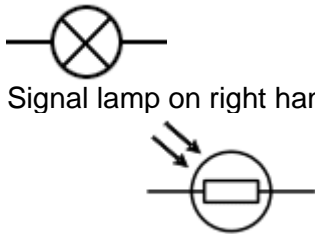
Question		Answer	Mark	Guidance
2	(a)	 <p>Signal lamp on right hand side of circuit diagram (1)</p> <p>LDR on left hand side of diagram (1)</p>	2	<p>Do not award one mark for filament lamp.</p> <p>Accept the LDR with or without an envelope.</p>
	(b)	The (two) npn transistors or two transistors.	1	Accept commercial names of transistors e.g. BC108, BFY51
	(c)	<p>The LDR and resistor R_1 act as a potential divider (1)</p> <p>During daylight the signal lamp will not light but as soon as darkness (1)/descends the LDR resistance increases and current flows (1).</p> <p>The emitter of the input transistor is connected directly to the base of the second. Both collectors are connected together. In this way the base current from the first transistor enters the base of the second. This results in a very high level of current gain (1).</p> <p>The overall current gain of the Darlington pair is the product of the two individual transistors. This means that if two transistors with modest current gains of 50 were used, then the overall current gain would be $50 \times 50 = 2500$.</p> <p>If the overall gain is large enough then the signal lamp will light (1).</p>	5	<p>Award up to five marks for an explanation that includes reference to:</p> <p>Potential divider LDR Darkness Current flow/gain/amplification Signal lamp.</p>
	(d)	When resistor R_1 is increased in value it has to be darker before the signal lamp will light.	1	
	(e)	The signal lamp comes on more slowly in the dark / the original current is being used to charge the capacitor.	1	Accept – signal lamp would not light so quickly.

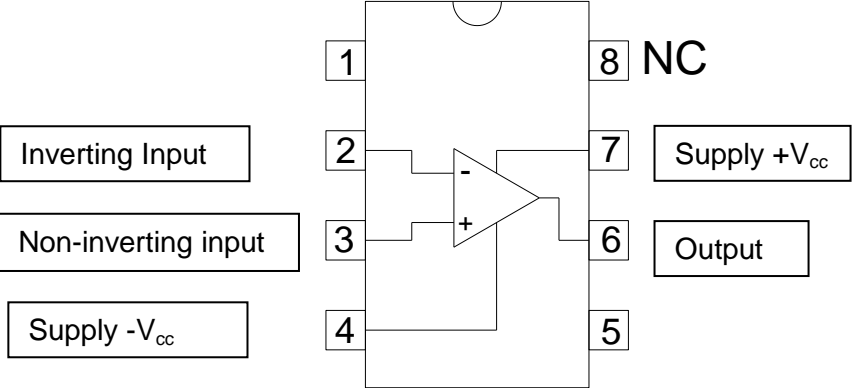
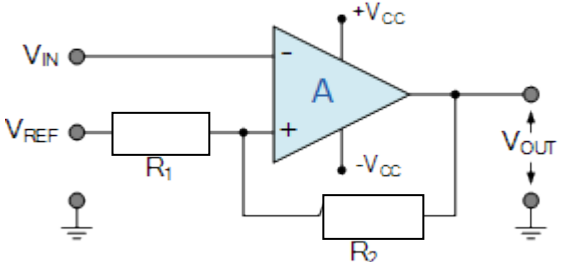
Question	Answer	Mark	Guidance
<p>3 (a)</p>		<p>5</p>	<p>Award one mark for each correct label up to a maximum of 5.</p>
<p>(b)</p>	<p>NC – Not Connected</p>	<p>1</p>	<p>Accept not in use.</p>
<p>(c)</p>	 <p>The op-amp voltage comparator compares the magnitudes of two voltage inputs (1) and determines which is the largest of the two (1).</p>	<p>5</p>	<p>Award three marks for the labelled diagram.</p> <p>Award one mark for the Op Amp. Award one mark for correct position of R_1. Award one mark for correct position of R_2.</p> <p>Award two marks for the description.</p>

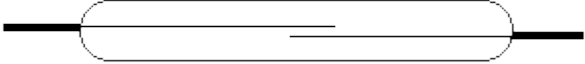
Question		Answer	Mark	Guidance
4	(a)	Switch A – Double Pole Double Throw Switch B – Toggle	2	Award one mark for each correct name.
	(b)		1	Accept as correct without envelope. Accept any other correct alternative response.
	(c)	Buzzer Solenoid	2	Award one mark for each correct output device.

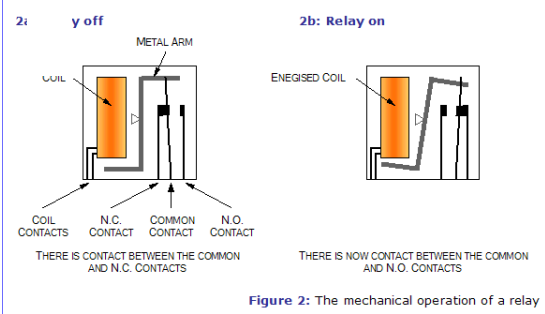
Question	Answer	Mark	Guidance
(d)	 <p>Figure 2: The mechanical operation of a relay</p> <p>Any 5 from:</p> <p>The electromechanical relay is an electrically operated switch. A small current passes through the coil contacts causing the coil to become an electromagnet (1)</p> <p>There are two sets of electrically conductive contacts which may be “Normally Open”, or “Normally Closed” (1)</p> <p>In the normally open position, the contacts are closed only when the field current is “ON” and the switch contacts are pulled towards the magnetised coil. (1)</p> <p>When current flows through the coil the metal arm is attracted to the coil with the common contact changing from NC contact to NO contact. (1)</p> <p>The circuit connected to the relay output is now turned on (1)</p> <p>The input and output circuits are isolated and can be at different voltages (1)</p> <p>(5x1)</p>	5	The diagram is shown for reference only.

Question		Answer	Mark	Guidance
5	(a)	<ul style="list-style-type: none"> Portable appliance testing (PAT) is a regular safety check (1) performed on portable electrical equipment or electrical appliances. (1) 	2	Accept safety check.
	(b)	<ul style="list-style-type: none"> Visual inspection Earth continuity test or continuity test. Insulation resistance test Polarity of live and neutral test Earth leakage test 	3	Accept any three correct responses.
	(c)	The earth is incomplete/not connected to the earth terminal (1) which makes the plug unsafe/dangerous. (1)	2	
	(d)	<ul style="list-style-type: none"> Appliance serial number Testers name or initials or identity number Date of next test 	2	Accept any two correct responses. Do not accept date of test – this is given in the question.

Question		Answer	Mark	Guidance
6	(a)	<p>Wave soldering is a bulk soldering process used in the manufacture of printed circuit boards.</p> <p>A conveyor carries a PCB with components in place which are preheated before going through a fluxing process. (1)</p> <p>The circuit board is passed over a pan of molten solder in which a pump produces an upwelling of solder that looks like a standing wave. (1)</p> <p>As the circuit board makes contact with this wave, the components become soldered to the board.(1)</p> <p>After this process the circuit board may require washing to remove flux traces. (1)</p>	4	<p>Award up to four marks for a description that includes reference to:</p> <ul style="list-style-type: none"> • Conveyor for reheating/fluxing • Pan of molten solder • Pump to produce waveform • Washing <p>For information only: Wave soldering is used for both through-hole printed circuit assemblies, and surface mount. In the latter case, the components are glued onto the surface of a printed circuit board (PCB) by placement equipment, before being run through the molten solder wave.</p>

Question	Answer	Mark	Guidance
<p>6 (b)*</p>	<p>A pick-and-place robot picks and places surface mount electronic components onto the PCB prior to soldering. Pick and Place robots use vacuum pickup tools to hold the components. The robot arm may also use vision-assisted alignment.</p> <p>In general, pick and place machines offer better speed, accuracy, higher quality and flexibility including picking up small components than manual component placement.</p> <p>They are especially practical in places such as assembly lines, where repetitive and difficult tasks need to be performed with accuracy, reducing human error. Surface mount components are difficult to place manually.</p> <p>Other advantages of using a pick and place robot is that it can get a job done faster than humans. This can lead to an increase in production rates, especially in industries where production is time-sensitive. Using these robots can also boost profits, because they can output more products in less time than a human can.</p> <p>A pick and place robot can be programmed and reprogrammed to complete a variety of functions. It can be programmed to handle multiple sizes of items or even different types of items. In addition, its thin arms, which can reach far, can be flexible enough to accommodate almost any type of product.</p> <p>Efficiency, consistency and accuracy are all benefits of using these types of robots. They can be specifically programmed, so their results will always be the same. The manufacturer will know that they will be as precise as they want them to be.</p>	<p>6</p>	<p>Level 3 (5–6 marks)</p> <ul style="list-style-type: none"> • Detailed discussion showing a thorough understanding of the advantages to a manufacturer of using pick and place robots for surface mount components rather than manual component placement. • Most advantages of pick and place robot method for soldering are given supported by relevant examples. • Information is presented clearly and accurately, with correct use of appropriate technical language and engineering terminology. • Accurate use of spelling, punctuation and grammar. <p>Level 2 (3–4 marks)</p> <ul style="list-style-type: none"> • Adequate discussion showing some understanding of the advantages to a manufacturer of using pick and place robots for surface mount components rather than manual component placement.. • Some advantages of pick and place robot methods for soldering are given supported by relevant examples. • Information is presented clearly and with some accuracy. • Appropriate technical language and engineering terminology is used on some occasions. • Occasional errors in spelling, punctuation and grammar.

Question	Answer	Mark	Guidance
	<p>Pick and place robots are slim by design. This allows manufacturers who incorporate them into their operations to conserve space that can be assigned to other uses. Some such robots might be able to be programmed to move within specific limits.</p> <p>Potential pick and place robot owners might want to research a robot's work envelope — the specific area where the robot can reach or move. This likely will determine how the manufacturer can use the robot. If a manufacturer desires to change how the robot moves, he might consider purchasing extensions for the robot's arms or changing its orientation.</p> <p>The safety of pick and place robots might also attract manufacturers'. The robots often perform tasks that can be repetitive and extremely tiring to the average worker, so robots can increase the safety of a working environment. These robots do not become tired, get distracted or require downtime to perform their programmed duties.</p> <p>Purchasing a pick and place robot might, at first, seem like an expensive investment, but manufacturers can recoup its cost in the long run. Money can be saved simply because a robot does not waste any material through mistakes. When productivity increases, profits will follow.</p>		<p>Level 1 (1–2 marks)</p> <ul style="list-style-type: none"> • Basic discussion showing limited understanding of the advantages to a manufacturer of using pick and place robots for surface mount components rather than manual component placement. • A few advantages of pick and place robot methods for soldering are given supported by relevant examples. • Information presented is basic and may be ambiguous or badly presented. • There will be little or no use of technical language and engineering terminology. • Errors of spelling, punctuation and grammar may be intrusive. <p>Level 0 (0 marks)</p> <ul style="list-style-type: none"> • A response that is irrelevant and/or not worthy of a mark. • Annotate with 'Seen' at end of response.

OCR (Oxford Cambridge and RSA Examinations)
1 Hills Road
Cambridge
CB1 2EU

OCR Customer Contact Centre

Education and Learning

Telephone: 01223 553998

Facsimile: 01223 552627

Email: general.qualifications@ocr.org.uk

www.ocr.org.uk

For staff training purposes and as part of our quality assurance programme your call may be recorded or monitored

Oxford Cambridge and RSA Examinations
is a Company Limited by Guarantee
Registered in England
Registered Office; 1 Hills Road, Cambridge, CB1 2EU
Registered Company Number: 3484466
OCR is an exempt Charity

OCR (Oxford Cambridge and RSA Examinations)
Head office
Telephone: 01223 552552
Facsimile: 01223 552553

© OCR 2016

