

**Advanced GCE
GEOLOGY**

F795 QP

Unit F795: Evolution of Life and Climate

Specimen Paper

Candidates answer on the question paper.

Time: 1 hour 45 mins

Additional Materials:

Scientific calculator
Ruler (cm / mm)

Candidate
Name

Centre
Number

--	--	--	--	--

Candidate
Number

--	--	--	--	--

INSTRUCTIONS TO CANDIDATES

- Write your name, Centre number and Candidate number in the boxes above.
- Answer **all** the questions.
- Use blue or black ink. Pencil may be used for graphs and diagrams only.
- Read each question carefully and make sure you know what you have to do before starting your answer.
- Do **not** write in the bar code.
- Do **not** write outside the box bordering each page.
- WRITE YOUR ANSWER TO EACH QUESTION IN THE SPACE PROVIDED.

INFORMATION FOR CANDIDATES

- The number of marks is given in brackets [] at the end of each question or part question.
-  Where you see this icon you will be awarded marks for the quality of written communication in your answer.
- You may use a scientific calculator.
- You are advised to show all the steps in any calculations.
- The total number of marks for this paper is **100**.

FOR EXAMINER'S USE		
Qu.	Max.	Mark
1	16	
2	14	
3	14	
4	15	
5	16	
6	13	
7	12	
TOTAL	100	

This document consists of **16** printed pages.

Answer **all** the questions.

1 Fossils **A** to **D** belong to the same group of fossils. The suture lines are shown below each fossil.

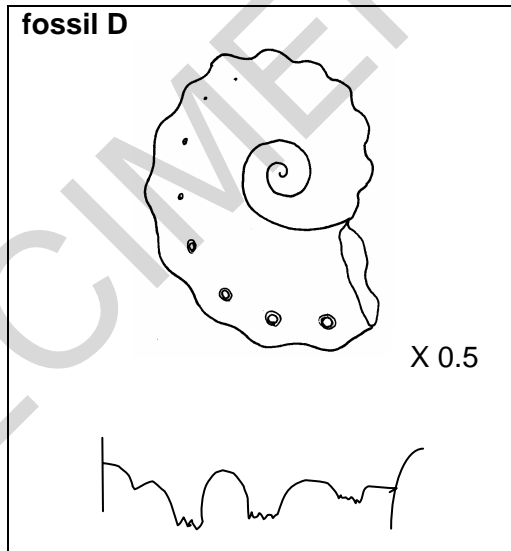
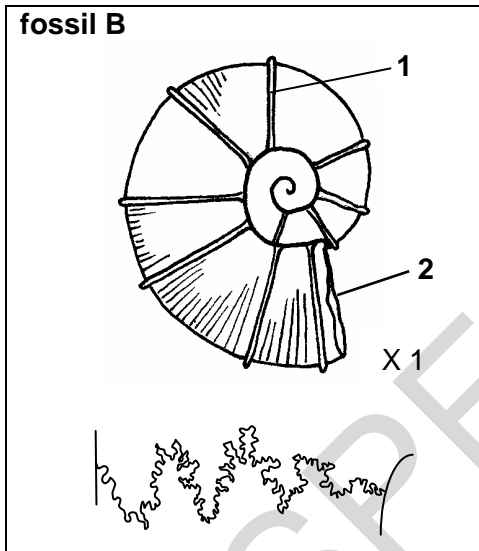
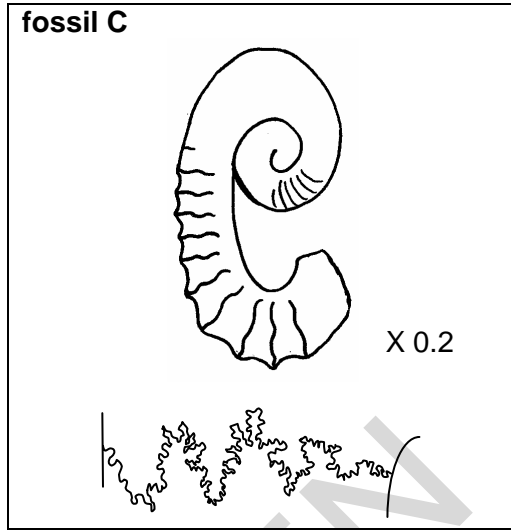
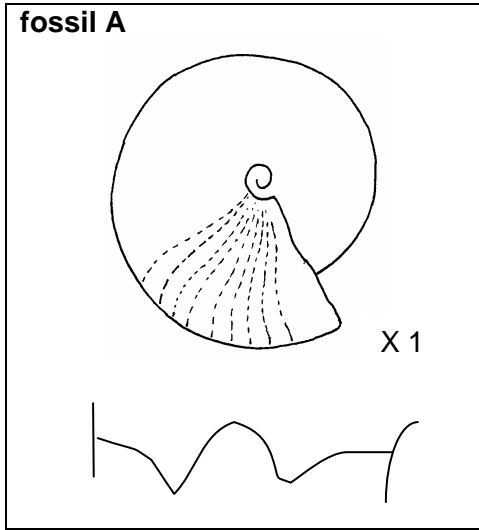

- (a) (i) To which group of cephalopods do fossils **A** to **D** belong?
 [1]
- (ii) Identify one of the fossils as a heteromorph.
 [1]
- (b) (i) Clearly identify the **two** morphological features on fossil **B**.
 1
 2 [2]

(ii) Using technical terms, compare the form of coiling in fossils **A** and **B**.

.....
.....
.....
..... [2]

(iii) Name the types of suture present in fossils **A** and **B**.

Fossil A
Fossil B [2]

(iv) Fossils **A**, **B** and **D** show an evolutionary trend. Put these fossils into age order.

youngest.....
oldest..... [2]

(c) Describe how Fossils **A** to **D** moved when they were alive.

.....
.....
.....
..... [2]

(d) Describe and explain the evolutionary changes that occurred in the ammonoids.

.....
.....
.....
.....
.....
.....
.....
..... [4]

[Total: 16]

[Turn over

- 2 (a) (i) Several descriptions are given below for different types of fossil preservation. Match the terms to the descriptions using the letters given.

description		term	description A, B, C, D or E
A	heat changes plant matter into carbon films by loss of volatiles during burial	replacement	
B	porous shells are replaced by SiO_2 from solution	carbonisation	
C	original shell is changed forming new crystals	silicification	
D	impressions of soft or hard parts, usually when original minerals have dissolved away	recrystallisation	
E	minerals deposited in pore spaces of shells, commonly CaCO_3 or iron minerals	moulds	

[4]

- (ii) Replacement by iron pyrites is called pyritisation. What environmental conditions are needed for this to occur?

.....

.....

.....

..... [2]

- (iii) Describe how some fossil invertebrate skeletons can contribute to the formation of limestone.

.....

.....

.....

..... [2]

(b) Describe the exceptional preservation of organisms in amber, tar and the Burgess Shale.

amber.....

.....

.....

.....

tar.....

.....

.....

.....

Burgess Shale

.....

.....

..... [6]

[Total : 14]

SPECIMEN

[Turn over

- 3 The diagram below shows the geological time scale and the fossil ranges for five invertebrate groups.

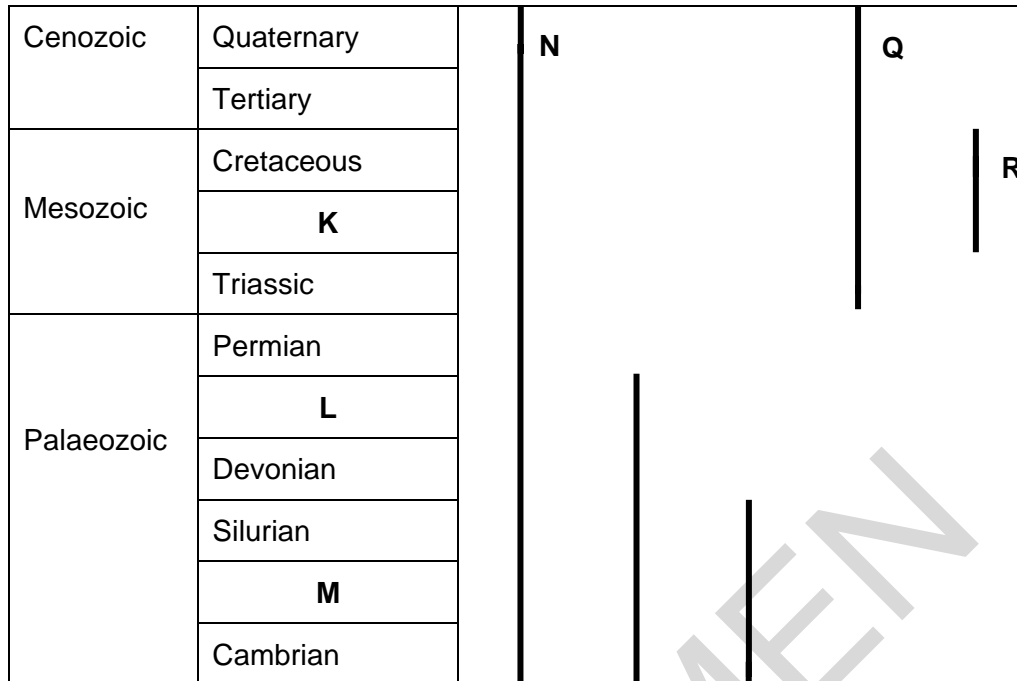

- (a) (i) State the geological systems that are represented by the following letters.

K.....

L.....

M..... [2]

- (ii) On the diagram below, complete the table with the letter of the appropriate range shown on the diagram above.

fossil group	range
trilobites	
ammonites	
graptolites	
scleractinian corals	
non-strophic brachiopods (short hinge)	

[4]

(b) A major extinction event occurs at the Cretaceous – Tertiary boundary.

(i) When was the Cretaceous – Tertiary mass extinction event?

..... Ma [1]

(ii) Describe **two** pieces of evidence that suggest the Cretaceous – Tertiary extinction event was caused by a large meteorite impact.

.....
.....
.....
..... [2]

(iii) Review the evidence for the volcanic activity of the Deccan traps of India as a possible cause for the Cretaceous – Tertiary mass extinction.

.....
.....
.....
..... [2]

(c) Describe how oxygen isotopes can be used to determine historic water temperature and hence past climate.

.....
.....
.....
.....
.....
..... [3]

[Total : 14]

[Turn over

4 Fossils **A** and **B** are echinoids.

fossil A

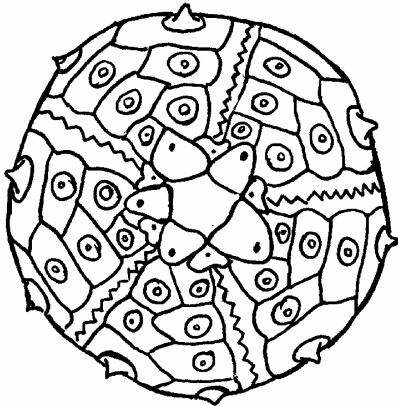

X 1

fossil B

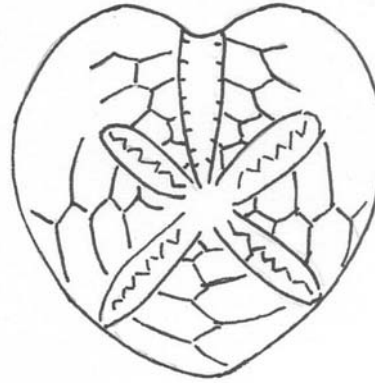

X 1

(a) (i) Label the following morphological features on either fossil **A** or **B** as appropriate.

- anterior groove
- anus
- apical system
- petaloid ambulacra

[4]

(ii) Shade **one** interambulacral plate, on one of the fossils **A** or **B**.

[1]

(iii) Describe a function of the following features, found in echinoids.

tube feet

.....

plastron.....

..... [2]

(b) Fossil **A** had large spines attached in life.

(i) To what morphological feature of the echinoid were spines attached?

..... [1]

(ii) Explain why the spines rarely remain attached to the echinoid after death.

.....

..... [1]

(iii) Describe the function of these echinoid spines.

..... [1]

(c) The length and width of 12 spines were recorded at one geological horizon. The results are shown in the table below.

spine number	length (mm)	width (mm)
1	10.5	2.4
2	12.0	2.6
3	11.5	3.0
4	12.0	2.3
5	11.8	2.5
6	11.0	2.5

spine number	length (mm)	width (mm)
7	13.0	1.5
8	12.0	1.5
9	11.8	1.2
10	14.0	1.3
11	14.0	1.0
12	15.0	1.5

(i) Plot the data as a scatter graph below.

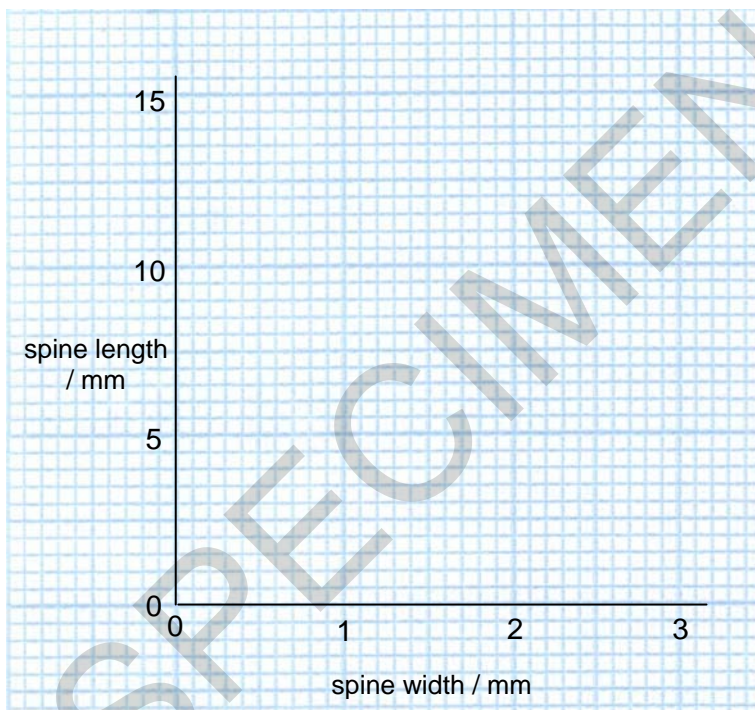

[2]

(ii) Describe and explain the patterns shown on your scatter graph.

.....

.....

.....

..... [2]

(d) Describe the environment that regular echinoids inhabit.

.....

..... [1]

[Total : 15]

[Turn over

5 The map below shows the distribution of both recent and fossil coral reefs.

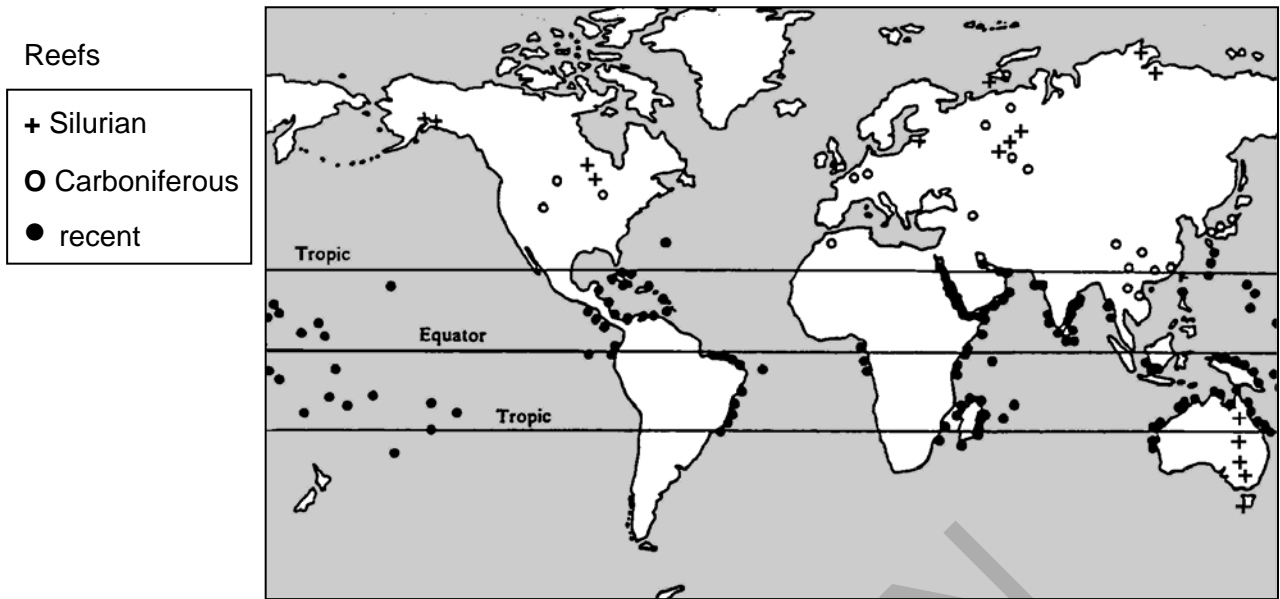

(a) (i) State **two** factors which control the distribution of **recent** coral reefs shown on the map.

.....

.....

.....

..... [2]

(ii) Explain why coral reefs are present in the centre of the Pacific Ocean.

.....

.....

.....

..... [2]

(iii) Describe the environmental conditions that are required for good coral growth and explain why corals are so sensitive to changes in the environment.

.....

.....

.....

.....

..... [3]

(iv) Explain what happens to coral reefs if the climate becomes warmer and if the sea level rises.

becomes warmer.....

.....

the sea level rises.....

..... [2]

(b) Draw labelled diagrams to show the difference between rugose and scleractinian corals. Explain how you would distinguish between them.

rugose coral

scleractinian coral



.....
.....
.....
..... [5]

(c) Rugose corals are found in both Carboniferous and Silurian reefs. Explain how the modern distribution of these corals can be used to show continental drift.

.....
.....
.....
..... [2]

[Total : 16]

[Turn over

.....

.....

.....

.....

.....

.....

.....

.....

.....

.....

.....

.....

.....

.....

.....

.....

.....

.....

.....

.....

.....

.....

[Total : 12]

Paper Total [100]

SPECIMEN

SPECIMEN

Copyright Acknowledgements:

Permission to reproduce items where third-party owned material protected by copyright is included has been sought and cleared where possible. Every reasonable effort has been made by the publisher (OCR) to trace copyright holders, but if any items requiring clearance have unwittingly been included, the publisher will be pleased to make amends at the earliest opportunity.

OCR is part of the Cambridge Assessment Group. Cambridge Assessment is the brand name of University of Cambridge Local Examinations Syndicate (UCLES), which is itself a department of the University of Cambridge.

© OCR 2007

The maximum mark for this paper is **100**.

SPECIMEN

Question Number	Answer	Max Mark												
1(a)(i)	Ammonoid / ammonite	[1]												
(ii)	Fossil C	[1]												
(b)(i)	Rib / ornament / <i>septum</i> Aperture	[2]												
(ii)	A is involute / B is evolute; A has a small umbilicus / B has a large umbilicus (any pair for 2 marks, one part for 1 mark); Planar / <i>planispiral</i> / in a plane (1 mark)	[2]												
(iii)	Fossil A – goniatitic / goniatite Fossil B – ammonitic / ammonite A simple and B complex / <i>frilly</i> (1 mark)	[2]												
(iv)	B D A 1 or 2 correct = 1; 3 correct = 2 marks	[2]												
(c)	Free swimmers / nektonic; Controlled gas levels / liquid levels in chambers; This allowed vertical movement; Used jet propulsion / squirted water; Fossil C is benthonic / crawled on sea floor; using tentacles;	Any 2 [2]												
(d)	Increased complexity of sutures / increase SA for attachment / <i>increase in strength</i> ; Needed to support the shells (thinner than nautiloid) / complex septa hold muscles tightly to prevent attack; Siphuncle migrates to outer margin of the shell / Septal necks point away from the protoconch; Allows easier control of gases for buoyancy; Increase in ornament or ribbing / strengthens shell against predators / pressure of water / sexual dimorphism; Increased coiling or <i>coiling changing from mainly involute to mainly evolute</i> / giving greater stability in the water column (they lack cameral deposits); Fossil C became uncoiled / adaptive radiation to live on the sea floor. Any 2 pairs, 1 for description and 1 for explanation Any 2 pairs	[4]												
	Total	[16]												
2(a)	<table border="1" style="margin-left: auto; margin-right: auto;"> <thead> <tr> <th data-bbox="459 1691 722 1809">term</th> <th data-bbox="722 1691 924 1809">description A,B,C,D or E</th> </tr> </thead> <tbody> <tr> <td data-bbox="459 1809 722 1854">replacement</td> <td data-bbox="722 1809 924 1854">E</td> </tr> <tr> <td data-bbox="459 1854 722 1899">carbonisation</td> <td data-bbox="722 1854 924 1899">A</td> </tr> <tr> <td data-bbox="459 1899 722 1944">silicification</td> <td data-bbox="722 1899 924 1944">B</td> </tr> <tr> <td data-bbox="459 1944 722 1989">recrystallisation</td> <td data-bbox="722 1944 924 1989">C</td> </tr> <tr> <td data-bbox="459 1989 722 2033">moulds</td> <td data-bbox="722 1989 924 2033">D</td> </tr> </tbody> </table>	term	description A,B,C,D or E	replacement	E	carbonisation	A	silicification	B	recrystallisation	C	moulds	D	
term	description A,B,C,D or E													
replacement	E													
carbonisation	A													
silicification	B													
recrystallisation	C													
moulds	D													

Question Number	Answer	Max Mark												
<p>2(a) cont'd</p>	<p>one correct = 1 mark two correct = 2 three correct = 3 four or five correct = 4</p> <p style="text-align: right;">Max 4</p>	<p>[4]</p>												
<p>(ii)</p>	<p>Anaerobic / anoxic sea floor; Sulphur fixing bacteria; Low energy; Iron pyrites forms on sea bed</p> <p style="text-align: right;">Any two</p>	<p>[2]</p>												
<p>(iii)</p>	<p>Fossils made of calcium carbonate / calcite / aragonite; Break into small fragments or fine sediment / crinoids break up or disarticulate Form part of fine particles that make up limestone; May be dissolved and redeposited elsewhere forming limestone</p> <p style="text-align: right;">Any two</p>	<p>[2]</p>												
<p>(b)</p>	<p><u>Amber</u> Resin flows down tree trapping organisms; preserves chitin or exoskeleton not soft tissue; hardens / recrystallises to form stable amber</p> <p style="text-align: right;">Any 2</p> <p><u>tar</u> Animals attracted to tar and fall in; Attracts other animals; Anaerobic / little decay / antiseptic properties</p> <p style="text-align: right;">Any 2</p> <p><u>Burgess Shale</u> Organisms lived on shelf; Landslide swept organisms into deeper water / obrution deposit; Deeper water anaerobic / little decay; replacement by clay minerals</p> <p style="text-align: right;">Any 2</p>	<p>[6]</p>												
	Total	[14]												
<p>3(a)(i)</p> <p>(ii)</p>	<p>K Jurassic L Carboniferous M Ordovician</p> <p style="text-align: right;">1 or 2 correct = 1; 3 correct = 2</p> <table border="1" data-bbox="327 1635 917 1870"> <thead> <tr> <th>Fossil group</th> <th>Range</th> </tr> </thead> <tbody> <tr> <td>Trilobites</td> <td>O or P</td> </tr> <tr> <td>Ammonites</td> <td>R</td> </tr> <tr> <td>Graptolites</td> <td>P or O</td> </tr> <tr> <td>Scleractinian Corals</td> <td>Q</td> </tr> <tr> <td>Brachiopods (short hinge)</td> <td>N</td> </tr> </tbody> </table> <p>1 correct = 1 mark 2 correct = 2 marks 3 correct = 3 marks 4 or 5 correct = 4 marks</p>	Fossil group	Range	Trilobites	O or P	Ammonites	R	Graptolites	P or O	Scleractinian Corals	Q	Brachiopods (short hinge)	N	<p>[2]</p> <p>[4]</p>
Fossil group	Range													
Trilobites	O or P													
Ammonites	R													
Graptolites	P or O													
Scleractinian Corals	Q													
Brachiopods (short hinge)	N													

Question Number	Answer	Max Mark
(b)(i)	65 Ma (+ / - 5 Ma)	[1]
(ii)	Chicxulub meteorite crater / present off the Gulf of Mexico; Tektites; Shocked quartz; High levels of iridium in boundary clays; Sedimentary evidence of widespread tsunamis;	[2]
(iii)	Large scale volcanic activity causes volcanic gases which could change the composition of the atmosphere; Acid rain could be formed and cause change in sea water / effect on vegetation Global implications on climate change explained due to dust / ash in the atmosphere blocking sunlight causing cooling	[2]
(c)	¹⁸ O is heavier than ¹⁶ O; More energy needed to vaporize / change from liquid to gas; Cooler marine water needs more energy to vaporize / has more O ¹⁸ ora Rain in ice ages has lower ¹⁸ O: ¹⁶ O; Rain in warmer periods has higher ¹⁸ O: ¹⁶ O; Temperature indicated by specific ratios so tropical is warmer, glacial colder	[3]
	Total	[14]
4(a)(i)	Anterior groove – fossil B, top indentation Anus – centre of fossil A / rear of fossil B Apical system – circular structures in centre of fossil A Petaloid ambulacra – petal structures on fossil B	[4]
(ii)	One complete plate with central tubercle on Fossil A / One complete plate adjacent to petaloid ambulacra on fossil B	[1]
(iii)	<u>Tube feet</u> Extension allows feeding / Respiratory function (1) <u>Plastron</u> Digging tool for making burrows (1)	[2]
(b)(i)	mamelon / spine boss / tubercle	[1]
(ii)	Soft tissue decays	[1]
(iii)	Allows movement and protection	[1]
(c)(i)	1 – 6 points correct = 1 7 – 12 points correct = 2	[2]
(ii)	Results show two distinct groupings; Representing two separate species; Description of length v width relationship; Reason given, eg growth or avp	[2]
(d)	High energy / rocky shore / littoral zone	[1]
	Total	[15]

Question Number	Answer	Max Mark														
<p>5(a)(i)</p> <p>(ii)</p> <p>(iii)</p> <p>(iv)</p> <p>(b)</p> <p>(c)</p>	<p>Latitude / near or on the tropics; Temperature of the water; Depth of water; Any 2</p> <p>Hot spot activity / magma rising to form submarine mounts; Water shallow enough for colonisation; Growth keeps pace with sinking as hot spot activity diminishes / formation of atolls Any 2</p> <p>Tropical conditions / 27°C / equatorial; High energy / well oxygenated water; Normal salinity; Low amount of detritus/ far from river mouths; Shallow / in photic zone; Any 2 symbiotic relationship of algae in modern corals requires light for photosynthesis. (1)</p> <p><u>becomes warmer</u> photosynthetic algae / enzymes unable to function in animal / bleached corals / corals die; (1)</p> <p><u>the sea level rises</u> Depth controls light levels / reduced light / Algae unable to photosynthesise (1)</p> <p>Recognisable drawings of rugose coral scleractinian coral (1) Any three suitable labels</p> <table border="0" data-bbox="327 1176 1157 1444"> <tr> <td>Scleractinian</td> <td>Rugose</td> </tr> <tr> <td>Tabulae sometimes present</td> <td>Tabulae always present</td> </tr> <tr> <td>Dissepiments always</td> <td>Dissepiments sometimes</td> </tr> <tr> <td>Radial symmetry</td> <td>Bilateral symmetry</td> </tr> <tr> <td>Not extinct</td> <td>Extinct</td> </tr> <tr> <td>No axial complex or rare</td> <td>Axial complex</td> </tr> <tr> <td>6 major septa at 6 points</td> <td>6 primary septa, septa at 4 points</td> </tr> </table> <p>Any two pairs as comparisons Any 4</p> <p>Now in N America and Europe and Australia in temperate latitudes; As corals only in tropical the continents must have moved; All part of Pangaea together south of equator in tropical area. Any 2</p>	Scleractinian	Rugose	Tabulae sometimes present	Tabulae always present	Dissepiments always	Dissepiments sometimes	Radial symmetry	Bilateral symmetry	Not extinct	Extinct	No axial complex or rare	Axial complex	6 major septa at 6 points	6 primary septa, septa at 4 points	<p>[2]</p> <p>[2]</p> <p>[3]</p> <p>[2]</p> <p>[5]</p> <p>[2]</p>
Scleractinian	Rugose															
Tabulae sometimes present	Tabulae always present															
Dissepiments always	Dissepiments sometimes															
Radial symmetry	Bilateral symmetry															
Not extinct	Extinct															
No axial complex or rare	Axial complex															
6 major septa at 6 points	6 primary septa, septa at 4 points															
	Total	[16]														
6	<p>Diagrams of pendent / two stiped form (1) Diagrams of biserial (1) Diagrams of scandent form (1) Diagrams of uniserial form (1) labels on diagrams (1) diagram marks No marks for dendroids</p> <p style="text-align: right;">Max 5</p>															

Question Number	Answer	Max Mark
6 cont'd	<p>Early forms Ordovician (1) had numerous branches/ to 4 stipes -/ Tetragraptus (1) Later Ordovician forms two-branched (pendant) forms/ didymograptus (1) Reclined or horizontal forms (1) single branched forms with thecae back-to-back (biserial)/ Diplograptus (1) mixed forms like / dicellograptus / scandent forms (1) single row of thecae forming single branch colonies (uniserial) / Monograptus (1) These are Silurian (1) The thecae evolved different distinctive shapes (1) Detail of simple / sigmoidal / hooked / isolate theca / details of thecal shapes (1) Diagrams of thecal shape (1) General evolution from forms with more branches and many individuals (1) to forms with few or with only one branch and very few individuals complex forms on curves and spirals (1) The direction of growth of the branches evolved from pendant to scandent (1) No diagrams = Max 10</p>	[13]
	QWC mark awarded for correct sequence of changes by age (1)	
7	<p>Establish absolute ages Isotopes are unstable and emit radioactive particles (1) Half of the parent element has formed daughter elements (1) Detail of half life graph (1) Explanation of how half lives are calculated using graph (1) Measurement of daughter and parent isotopes needed / ratio found (1) Date given in millions of years (1) ^{40}K decays to ^{40}Ar with half life is 11,900 - 12,000 Ma (1) ^{238}U decays to ^{206}Pb with half life is 4 500 Ma (1) OR ^{235}U decays to ^{207}Pb with half life 710 Ma (1) Date radioactive minerals in rocks (1) Example of minerals containing radioactive elements eg mica, sphene (1) Max 6</p> <p>Problems of radiometric dating Whole rock dating / overprinting problems Glauconite in sedimentary rocks Problems due to loss of gases by weathering eg Argon Metamorphism resets geological clock Dating sedimentary rocks dates the fragments not the formation Don't know the accuracy of radiometric techniques / mass spectrometer Initial amounts of isotope difficult to determine Comments on margin of error for methods. Max 6</p>	[12]
	QWC mark awarded for correct sequence of changes by age (1)	
	Paper Total	[100]

QWC is applied across questions 6 and 7 where the extended writing requires the candidates to choose the structure, style and specialist terms used.

3 marks	Information is organised clearly and coherently, so that the candidate communicates effectively, uses a wide range of specialist terms with precision and spelling, punctuation and grammar are accurate so that the meaning is clear. The form and style of writing are appropriate to purpose and to complex subject matter.
2 marks	Information is organised, uses some specialist terms and spelling, punctuation and grammar are accurate so that the meaning is clear. The form and style of writing are appropriate to purpose and to complex subject matter.
1 mark	Information is poorly organised with a limited range of specialist terms used appropriately and spelling, punctuation and grammar are generally accurate with few errors.
0 marks	Organisation is poor, leading to a failure to communicate knowledge and ideas. There are significant errors in the use of language, spelling, punctuation and grammar which makes the candidate's meaning uncertain.

Assessment Objectives Grid (includes QWC)

Question	AO1	AO2	AO3	Total
1(a)(i)	1			1
1(a)(ii)		1		1
1(b)(i)		2		2
1(b)(ii)		2		2
1(b)(iii)	1	1		2
1(b)(iv)		2		2
1(c)	2			2
1(d)	4			4
2(a)(i)		4		4
2(a)(ii)	2			2
2(a)(iii)		2		2
2(b)	6			6
3(a)(i)	2			2
3(a)(ii)		4		4
3(b)(i)	1			1
3(b)(ii)		2		2
3(b)(iii)		2		2
3(c)		3		3
4(a)(i)	2	2		4
4(a)(ii)		1		1
4(a)(iii)	2			2
4(b)(i)	1			1
4(b)(ii)	1			1
4(b)(iii)	1			1
4(c)(i)			2	2
4(c)(ii)			2	2
4(d)	1			1
5(a)(i)		2		2
5(a)(ii)	1		1	2
5(a)(iii)	3			3
5(a)(iv)		2		2
5(b)		1	4	5
5(c)		2		2
6	3	9	1	13
7	3	9		12
Totals	37	53	10	100