

EXTERNAL ASSESSMENT SAMPLE TASKS  
WELSH

**BREAKTHROUGH**

# Asset Languages

## External Assessment Sample Tasks Breakthrough Stage Listening and Reading

### WELSH

<b>Contents</b>	<b>Page</b>
Introduction	2
Listening Sample Tasks	3
Tapescripts	6
Listening – Answer Key	9
Reading Sample Tasks	10
Reading – Answer Key	12

## INTRODUCTION

In this booklet, two sample tasks are provided for each of the skills of:

- Listening
- Reading

The two Listening and Reading Welsh sample tasks in this booklet have been produced to give you a better idea of the style of Asset Languages Breakthrough Stage External Assessment. These tasks are based on the sample external assessment materials in English on the website. Asset Languages live tests will contain tasks of the same format as the tasks provided here.

For more information on the content of the Breakthrough external assessments, please refer to the Introductory Stage Guide which is available on the Asset Languages website. Language specifications are also available and these show the language purposes and functions that are in external tests for each language.

Asset Languages regularly receives feedback from centres and candidates as well as statistical information from candidates' live test responses. We take this information into account and, over time, tests may be adapted and new task types introduced.

# LISTENING SAMPLE TASK

## Part 1

Questions 1-5

Look at the pictures. Choose the one you hear. Put a tick (✓) in the box.

1

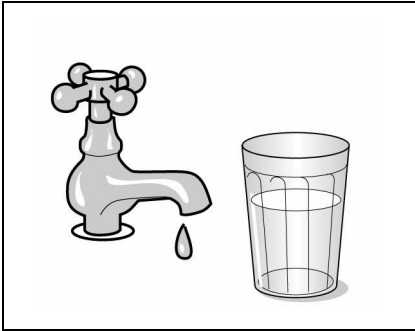

A



B

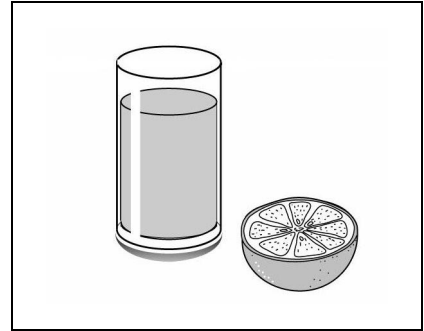

C

2

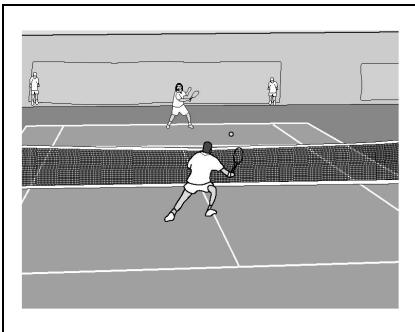

A

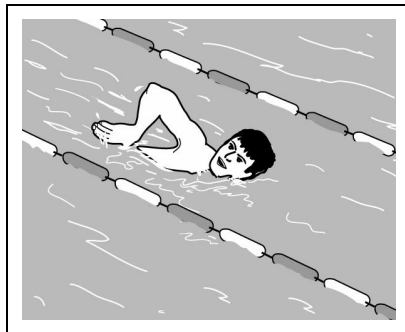

B



C

3

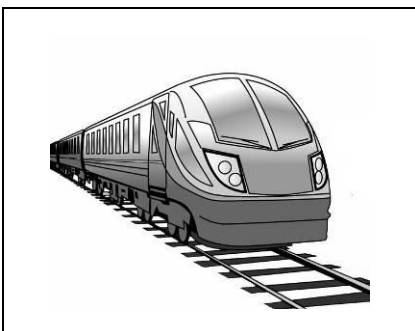

A

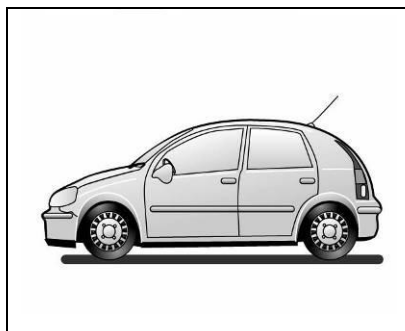

B

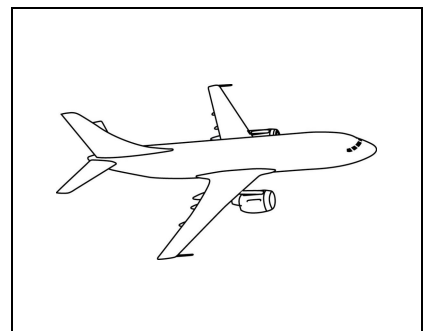

C

LISTENING SAMPLE TASK

4

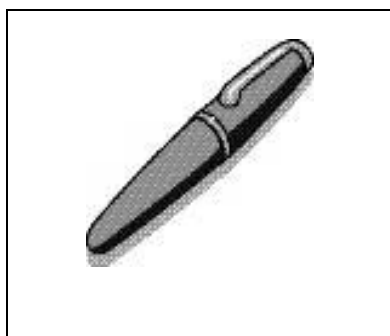

A

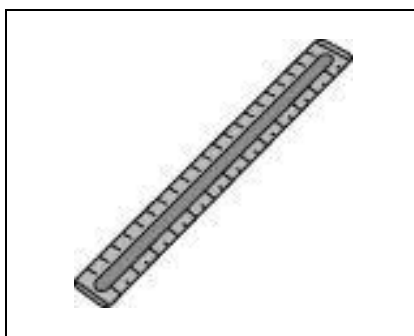

B



C

5



A



B

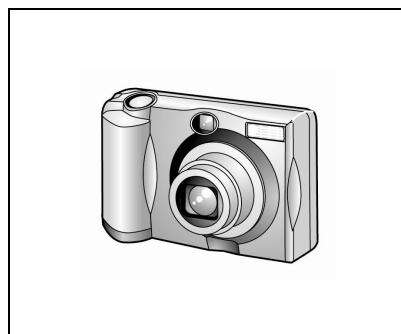

C

# LISTENING SAMPLE TASK

## Part 3

### Questions 11–15

You will hear Carys talking about her plans. Look at the pictures. What is Carys doing this week?

Listen and choose the correct picture for each day. Write a letter (A–F) in the box. There is one extra picture you do not need to use.

11 Monday

12 Tuesday

13 Wednesday

14 Thursday

15 Friday

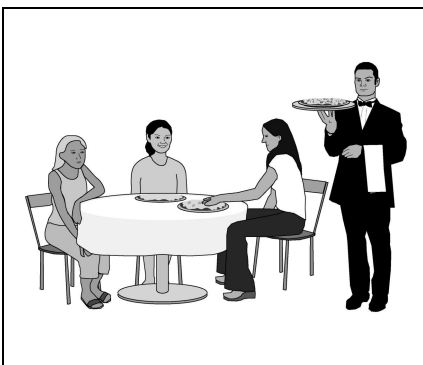

A



B

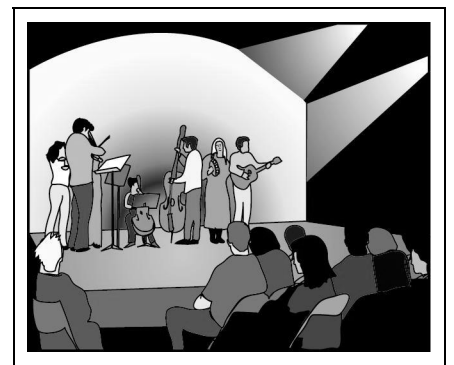

C



D

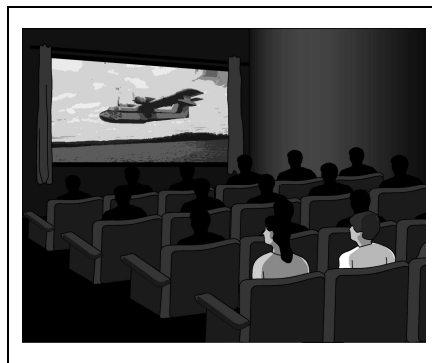

E

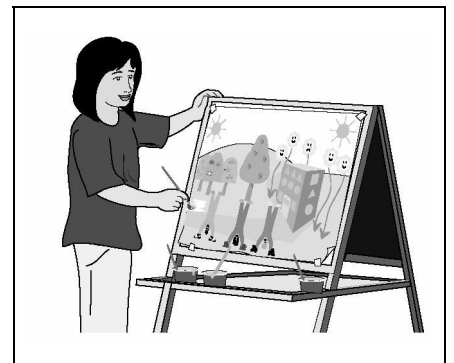

F

## LISTENING SAMPLE TASK

R Now open your question paper and look at Part One.  
Look at the pictures. Choose the one you hear. Put a tick in the box.  
You will hear each question twice.

**PAUSE 00'03''**

R One.

M *Hoffwn i gael coffi.*

**PAUSE 00'03''**

**[REPEAT QUESTION ONE]**

**PAUSE 00'03''**

R Two.

F *Dw i'n hoffi tenis.*

**PAUSE 00'03''**

**[REPEAT QUESTION TWO]**

**PAUSE 00'03''**

R Three.

M *Gadewch i ni fynd yn y car.*

**PAUSE 00'03''**

**[REPEAT QUESTION THREE]**

**PAUSE 00'03''**

R Four.

F *Dyma fy mhensil i.*

**PAUSE 00'03''**

**[REPEAT QUESTION FOUR]**

**PAUSE 00'03''**

R Five.

M *Dyna fy nghêsi!*

**PAUSE 00'03''**

**[REPEAT QUESTION FIVE]**

**PAUSE 00'03''**

R That is the end of Part One.

**PAUSE 00'05''**

## LISTENING SAMPLE TASK

R Part Three.  
You will hear Carys talking about her plans. Look at the pictures. What is Carys doing this week? Listen and choose the correct picture for each day. Write a letter, A to F, in the box. There is one extra picture you do not need to use. You will hear the whole conversation twice.

**[REPEAT FROM HERE]**

**PAUSE 00'03''**

R Eleven.

M *Carys, beth wyt ti'n wneud ddydd Llun?*

F *Dw i'n mynd i'r sinema.*

M *O ie, mae ffilm dda ymlaen.*

**PAUSE 00'06''**

R Twelve.

M *A dydd Mawrth?*

F *Wel, dw i'n mynd i ddawnsio.*

M *Wyt ti'n mynd i'r clwb nos newydd?*

F *Ydw, dw i'n ei hoffi fe.*

**PAUSE 00'06''**

R Thirteen.

M *A dydd Mercher?*

F *Dw i'n mynd i brynu dillad newydd.*

M *Wrth gwrs, mae'r siopau'n cau yn hwyr.*

**PAUSE 00'06''**

R Fourteen.

M *Beth wyt ti'n wneud ddydd Iau?*

F *Dw i'n mynd i fy nosbarth celf i. Dw i'n peintio llun i fy mam.*

**PAUSE 00'06''**

R Fifteen.

M *A dydd Gwener?*

F *Wel, dw i'n mynd i gyngerdd.*

M *Pwy sy'n chwarae?*

## LISTENING SAMPLE TASK

F *Band lleol newydd.*

**PAUSE 00'06''**

R Now listen again.

**[REPEAT PART THREE WITH 00'03'' PAUSES]**

**PAUSE 00'03''**

R That is the end of Part Three.

## LISTENING – ANSWER KEY

### Answer Key

Part 1	
1	B
2	A
3	B
4	C
5	A
Part 3	
11	E
12	D
13	B
14	F
15	C

## READING SAMPLE TASK

### Part 2

#### Questions 6–10

You are going to answer some questions about a young girl. Complete the questions by choosing an answer (A–F) and mark it on the separate answer sheet. There is one letter you do not need to use.

A school day	
6 <i>Beth ydy dy enw di?</i>	<input type="checkbox"/>
7 <i>Ble wyt ti'n byw?</i>	<input type="checkbox"/>
8 <i>Pryd wyt ti'n codi?</i>	<input type="checkbox"/>
9 <i>Beth wyt ti'n gael i frecwast?</i>	<input type="checkbox"/>
10 <i>Sut wyt ti'n mynd i'r ysgol?</i>	<input type="checkbox"/>

A *creision ŷd*

B *mewn car*

C *Mair*

D *am hanner awr wedi saith*

E *nofio*

F *mewn tre fawr*

READING SAMPLE TASK

Part 5

Questions 21-25

Read about Bryn, Seimon and Alun.

Answer the questions by marking a letter, A, B or C, on the separate answer sheet.

A

**Bryn**

*Mae Bryn yn un deg tri oed, gyda\* gwallt brown byr. Mae e'n byw mewn tŷ semi. Mae teledu yn ei ystafell wely e. Yn yr ysgol mae e'n hoffi mathemateg.*

B

**Seimon**

*Mae Seimon yn un deg pedwar oed, gyda\* gwallt du byr. Mae e'n byw mewn fflat. Mae gyda fe\*\* gyfrifiadur a chwaraewr CD. Arlunio ydy ei hoff bwnc e.*

C

**Alun**

*Mae Alun yn un deg tri oed gyda\* gwallt du hir. Mae e'n byw mewn tŷ mawr. Mae gyda fe\*\* gyfrifiadur yn ei ystafell wely e. Ei hoff bwnc e ydy Saesneg.*

\*gyda = efo

\*\*gyda fe = ganddo fo

21 Who is fourteen years old?

22 Who has long hair?

23 Who lives in a big house?

24 Who has a television in his room?

25 Who likes art?

## READING – ANSWER KEY

### Answer Key

Part 2	
6	C
7	F
8	D
9	A
10	B
Part 5	
21	B
22	C
23	C
24	A
25	B