

Thursday 26 January 2012 – Afternoon

GCSE METHODS IN MATHEMATICS

B392/02 Methods in Mathematics 2 (Higher Tier)

Candidates answer on the Question Paper.

OCR supplied materials:

None

Other materials required:

- Scientific or graphical calculator
- Geometrical instruments
- Tracing paper (optional)

Duration: 2 hours



Candidate forename		Candidate surname	
--------------------	--	-------------------	--

Centre number						Candidate number				
---------------	--	--	--	--	--	------------------	--	--	--	--

INSTRUCTIONS TO CANDIDATES

- Write your name, centre number and candidate number in the boxes above. Please write clearly and in capital letters.
- Use black ink. HB pencil may be used for graphs and diagrams only.
- Answer **all** the questions.
- Read each question carefully. Make sure you know what you have to do before starting your answer.
- Your answers should be supported with appropriate working. Marks may be given for a correct method even if the answer is incorrect.
- Write your answer to each question in the space provided. Additional paper may be used if necessary but you must clearly show your candidate number, centre number and question number(s).
- Do **not** write in the bar codes.

INFORMATION FOR CANDIDATES

- The number of marks is given in brackets [] at the end of each question or part question.
- Your Quality of Written Communication is assessed in questions marked with an asterisk (*).
- The total number of marks for this paper is **90**.
- This document consists of **20** pages. Any blank pages are indicated.

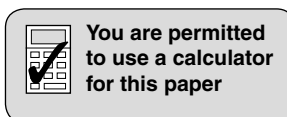

This paper has been pre modified for carrier language

Formulae Sheet: Higher Tier

Area of trapezium = $\frac{1}{2}(a + b)h$

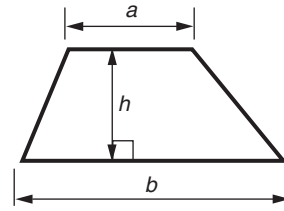

Volume of prism = (area of cross-section) \times length

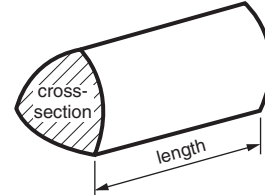

In any triangle ABC

Sine rule $\frac{a}{\sin A} = \frac{b}{\sin B} = \frac{c}{\sin C}$

Cosine rule $a^2 = b^2 + c^2 - 2bc \cos A$

Area of triangle = $\frac{1}{2}ab \sin C$

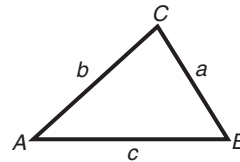

Volume of sphere = $\frac{4}{3}\pi r^3$

Surface area of sphere = $4\pi r^2$

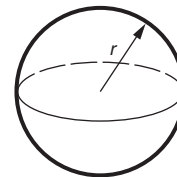

Volume of cone = $\frac{1}{3}\pi r^2 h$

Curved surface area of cone = $\pi r l$

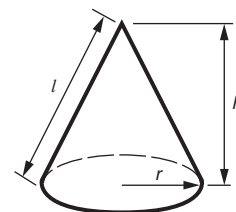

The Quadratic Equation

The solutions of $ax^2 + bx + c = 0$,
where $a \neq 0$, are given by

$$x = \frac{-b \pm \sqrt{b^2 - 4ac}}{2a}$$

PLEASE DO NOT WRITE ON THIS PAGE

- 1 (a) Work out 15% of £21.60.

(a) £ _____ [2]

- (b) Kelvin earns £6.50 per hour.
He gets a 2% wage rise.

How much per hour will Kelvin earn after the wage rise?

(b) £ _____ [2]

- (c) Aisha is doing a science experiment about plant growth.
A leaf is 25 mm long at the start of the experiment.
At the end of the experiment, the leaf is 29 mm long.

What is the percentage increase in the length of the leaf?

(c) _____ % [3]

2 (a) The n th term of a sequence is $6n - 1$.

(i) Write down the first two terms of the sequence.

(a)(i) _____ , _____ [2]

(ii) How many terms in the sequence are smaller than 100?

(ii) _____ [3]

(b) Find an expression for the n th term of this sequence.

5, 8, 11, 14, 17, ...

(b) _____ [2]

- 3 A is the point (0, 0). B is the point (2, 3).
AB is the diameter of a circle.

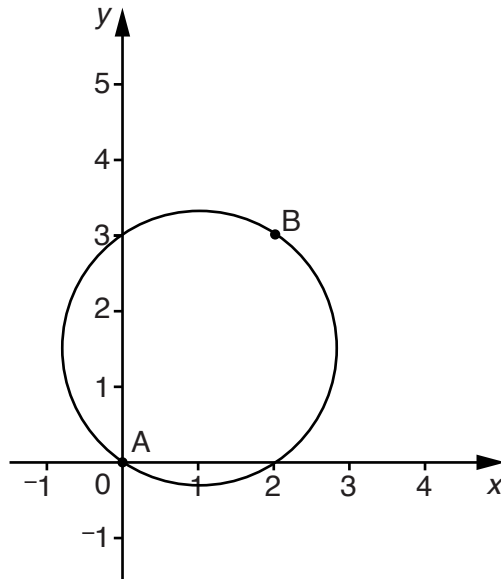

- (a) Show that the length of AB is 3.6 units, correct to 1 decimal place.

[3]

- (b) Work out the circumference of the circle.

(b) _____ units [2]

4 (a) Solve.

$$2(x + 5) = 3$$

(a) _____ [2]

(b) (i) Make m the subject of this formula.

$$d = \frac{m}{v}$$

(b)(i) _____ [1]

(ii) Make b the subject of this formula.

$$A = \frac{1}{2}bh$$

(ii) _____ [2]

5 A pile of 6 identical textbooks is 15.9 cm high.

(a) How high will a pile of 10 of these textbooks be?

(a) _____ cm [2]

(b) A shelf space is 23 cm high.

How many of the textbooks could be put in a single pile in this space?

(b) _____ [2]

6 (a) Work out.

(i) 2.3^4

(a)(i) _____ [1]

(ii) $\sqrt{(1.44 \times 10^8)}$

(ii) _____ [1]

(b) Write this ratio in its simplest form.

175 : 190

(b) _____ [2]

7* Janice is using these numbers to make a new number.



She can only use +, −, ×, ÷ and brackets to combine the numbers.

- She cannot use any number more than once.
- She cannot use powers.
- She cannot put digits together, eg she can't use 145.

What is the biggest number Janice can make?

Show how she can make this number.

[4]

8 (a) Find the values of x and y .

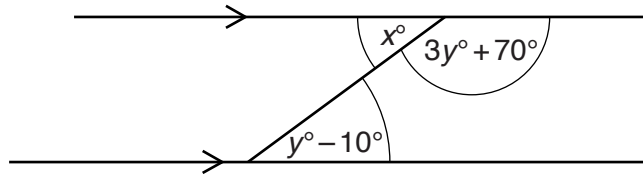

(a) $x =$ _____ , $y =$ _____ [5]

- (b) The diagram shows a shaded regular heptagon. The sides of the heptagon are extended to make a star.

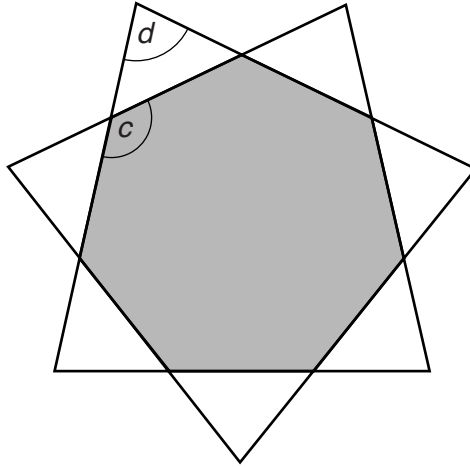

Calculate the size of angles c and d .
Give your answers as mixed numbers.

(b) $c = \text{_____}^\circ$, $d = \text{_____}^\circ$ [5]

- 9 In this triangle, $PQ = 14.4$ cm, $QR = 6$ cm and angle $PQR = 90^\circ$.

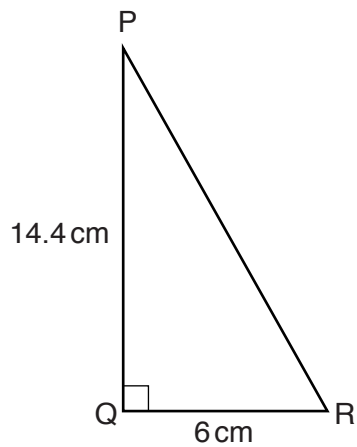

Not to scale

Calculate the size of angle PRQ.
Write your answer correct to one decimal place.

_____ ° [3]

- 10** A square and a rectangle are drawn below.
 The square has side x cm.
 The length of the rectangle is 1 cm more than the length of the square.

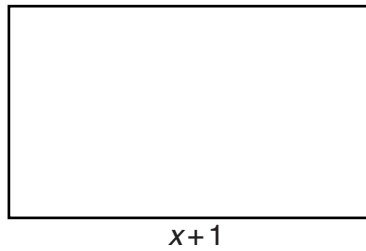
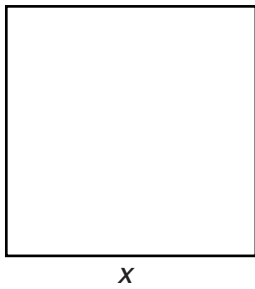

Not to scale

The perimeter of the rectangle is equal to the perimeter of the square.

- (a)** Show that the width of the rectangle is $(x - 1)$ cm.

_____ [1]

- (b)*** Prove that the area of the rectangle is smaller than the area of the square.

 _____ [3]

- 11** Write down the type of algebraic statement for each of the following.
 Choose from the words in this list.

Equation Inequality Formula Identity Expression

(a) $2x + 1 = 5$

(a) _____ [1]

(b) $3x^2 - 4$

(b) _____ [1]

(c) $3(2x - 4) = 6x - 12$

(c) _____ [1]

12 (a) Expand the brackets and simplify.

$$(3x - 2)(2x + 1)$$

(a) _____ [3]

(b) Factorise completely.

$$2x^2 - 8$$

(b) _____ [2]

(c) Solve.

$$2x^2 - 7x + 3 = 0$$

(c) _____ [3]

13 Work out the following. Give your answer as a fraction.

$$0.\dot{4}\dot{5} - 0.\dot{3}$$

_____ [2]

14 ABCD, AEFB and FJCH are squares.

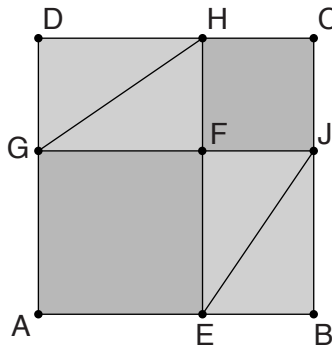

Prove that triangles HFG and JFE are congruent.

_____ [3]

- 15** m is directly proportional to the square root of p .
When $p = 4$, $m = 10$.

(a) Find m when $p = 6.25$.

(a) _____ [4]

(b) Find p when $m = 100$.

(b) _____ [2]

16 ABC is a sector of a circle with centre A.

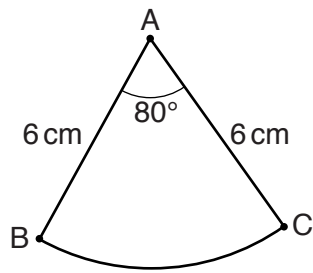

Not to scale

(a) Calculate the length of the arc BC.

(a) _____ cm [3]

(b) Edge AB is joined to edge AC to make a cone.

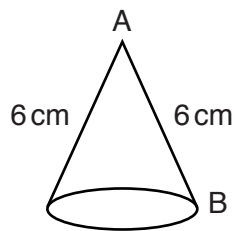

Calculate the angle between AB and the base of the cone.

(b) _____ ° [4]

- 17 This circle has radius 1 and centre the origin, O .
 P is a point on the circle, with coordinates (h, k) .
 θ is the anticlockwise angle from the positive x -axis to OP .

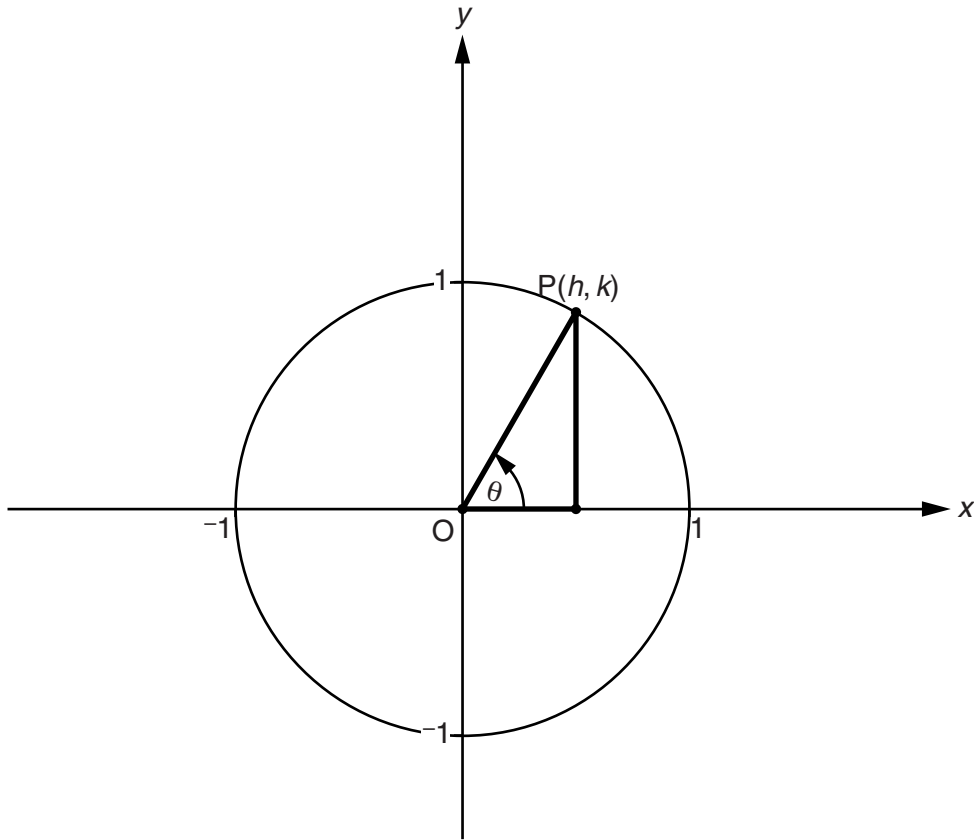

Sketch a graph to show how h changes as θ increases.

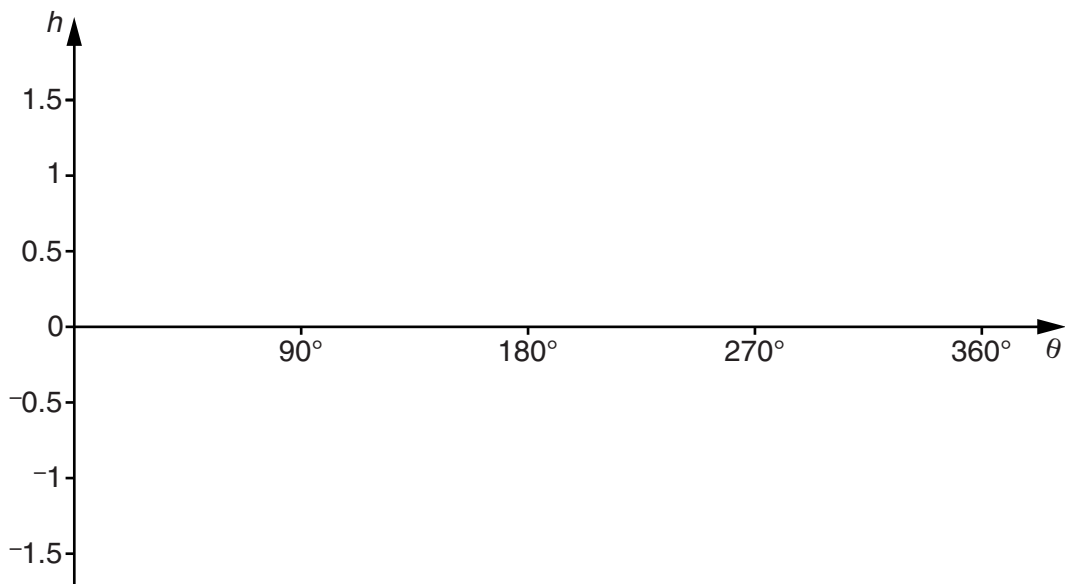

[2]

- 18 The diagram shows a pyramid with a square base.
 The side of the square base is 4 cm.
 The perpendicular height of the pyramid is 7.5 cm.

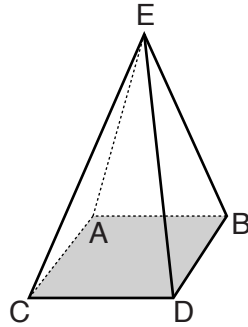

- (a) The volume of a pyramid = $\frac{1}{3} \times$ base area \times perpendicular height.

Calculate the volume of the pyramid.

(a) _____ cm³ [2]

- (b) The top of the pyramid is cut off to leave a frustum.
 Square FGHIJ has side 2 cm.

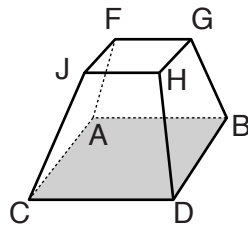

Calculate the volume of the frustum.

(b) _____ cm³ [4]

BLANK PAGE

PLEASE DO NOT WRITE ON THIS PAGE

PLEASE DO NOT WRITE ON THIS PAGE



Copyright Information

OCR is committed to seeking permission to reproduce all third-party content that it uses in its assessment materials. OCR has attempted to identify and contact all copyright holders whose work is used in this paper. To avoid the issue of disclosure of answer-related information to candidates, all copyright acknowledgements are reproduced in the OCR Copyright Acknowledgements Booklet. This is produced for each series of examinations and is freely available to download from our public website (www.ocr.org.uk) after the live examination series.

If OCR has unwittingly failed to correctly acknowledge or clear any third-party content in this assessment material, OCR will be happy to correct its mistake at the earliest possible opportunity.

For queries or further information please contact the Copyright Team, First Floor, 9 Hills Road, Cambridge CB2 1GE.

OCR is part of the Cambridge Assessment Group; Cambridge Assessment is the brand name of University of Cambridge Local Examinations Syndicate (UCLES), which is itself a department of the University of Cambridge.