

Thursday 16 June 2016 – Afternoon

GCSE METHODS IN MATHEMATICS

B392/01 Methods in Mathematics 2 (Foundation Tier)

Candidates answer on the Question Paper.

OCR supplied materials:

None

Other materials required:

- Scientific or graphical calculator
- Geometrical instruments
- Tracing paper (optional)

Duration: 1 hour 30 minutes



Candidate forename		Candidate surname	
--------------------	--	-------------------	--

Centre number						Candidate number				
---------------	--	--	--	--	--	------------------	--	--	--	--

INSTRUCTIONS TO CANDIDATES

- Write your name, centre number and candidate number in the boxes above. Please write clearly and in capital letters.
- Use black ink. HB pencil may be used for graphs and diagrams only.
- Answer **all** the questions.
- Read each question carefully. Make sure you know what you have to do before starting your answer.
- Your answers should be supported with appropriate working. Marks may be given for a correct method even if the answer is incorrect.
- Write your answer to each question in the space provided. If additional space is required, you should use the lined page(s) at the end of this booklet. The question number(s) must be clearly shown.
- Do **not** write in the bar codes.

INFORMATION FOR CANDIDATES

- The number of marks is given in brackets [] at the end of each question or part question.
- Quality of written communication will be assessed in questions marked with an asterisk (*).
- The total number of marks for this paper is **90**.
- This document consists of **20** pages. Any blank pages are indicated.

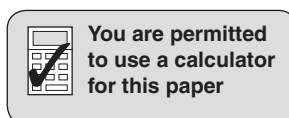

You are permitted to use a calculator for this paper

Formulae Sheet: Foundation Tier

Area of trapezium = $\frac{1}{2} (a + b)h$

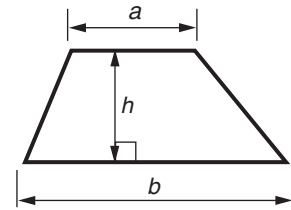

Volume of prism = (area of cross-section) \times length

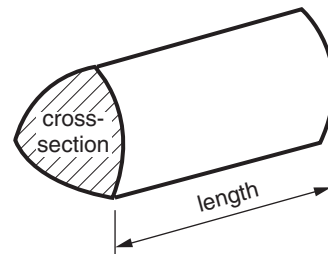

PLEASE DO NOT WRITE ON THIS PAGE

Answer **all** the questions.

1 Quadrilateral PQRS is drawn on a one-centimetre grid.

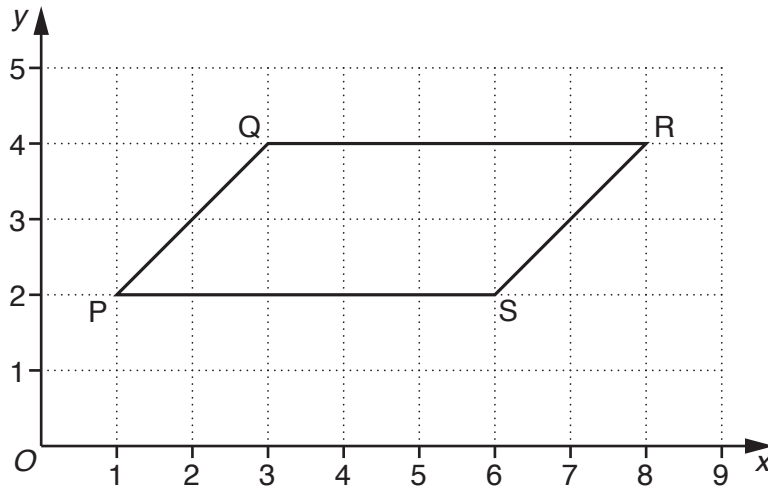

(a) What is the mathematical name for quadrilateral PQRS?

(a) [1]

(b) Work out the area of quadrilateral PQRS.

(b) cm² [2]

(c) Write down the coordinates of points P and R.

(c) P (..... ,) [1]

R (..... ,) [1]

(d) Work out the coordinates of the midpoint of the diagonal PR.

(d) (..... ,) [2]

2 Solve.

(a) $x - 14 = 21$

(a) [1]

(b) $x + 57 = 120$

(b) [1]

(c) $5x = 80$

(c) [1]

3 (a) Find the next three terms of each sequence.

(i) 26, 21, 16, 11,,, [2]

(ii) 2, 6, 18, 54,,, [2]

(b)* These are the first five terms of another sequence.

3 14 25 36 47

Lucy says, 'The 6th term of the sequence is 58 and so I just have to double 58 to find the 12th term.'

Show that Lucy is **not** correct.

.....
.....
.....
..... [2]

4 Work out.

(a) $\frac{2}{3}$ of £342

(a) £ [2]

(b) 25% of £64

(b) £ [2]

(c) 40% of £280

(c) £ [2]

5 Work out the value of these expressions when $r = 3$, $s = 5$ and $t = -7$.

(a) $6r$

(a) [1]

(b) $r - t$

(b) [1]

(c) s^3

(c) [1]

(d) $r(s + t)$

(d) [2]

- 6 A supermarket sells chicken pieces in different pack sizes.
Pack A has 3 pieces and pack B has 5 pieces.

Rob and Sai are planning a party and they need exactly 28 pieces of chicken.

- (a) Rob suggests they buy one pack A and five pack Bs.
Sai suggests a different way to buy exactly 28 pieces of chicken.

Find the way Sai suggests.

(a) pack A and pack B [2]

- (b) Pack A costs £1.45 and pack B costs £2.40.

Work out whose suggestion is cheaper and by how much.

(b) suggestion is cheaper by [4]

- 7 (a) ABC is an isosceles triangle, with $BC = BA$.
Angle $BCA = 40^\circ$.

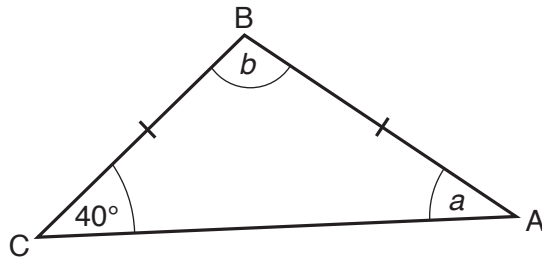

Not to scale

Work out angle a and angle b .

(a) $a = \dots\dots\dots^\circ$ [1]

$b = \dots\dots\dots^\circ$ [1]

- (b) PQRS is a quadrilateral. PST is a straight line.
Angle $QPS = 70^\circ$, angle $PQR = 120^\circ$ and angle $RSP = 25^\circ$.

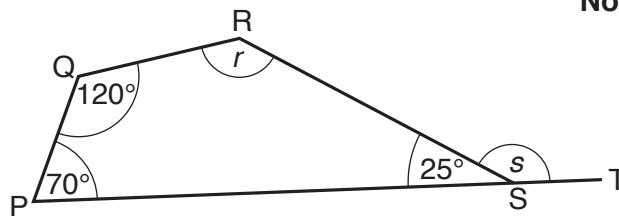

Not to scale

Work out angle r and angle s .

(b) $r = \dots\dots\dots^\circ$ [2]

$s = \dots\dots\dots^\circ$ [2]

8

8 Barry thinks that these two calculations give the same answer.

$$578^2 - 312^2 \quad \text{and} \quad (578 - 312)(578 + 312)$$

Rebecca thinks that these two calculations give the same answer.

$$8.6^2 - 3.4^2 \quad \text{and} \quad (8.6 - 3.4)(8.6 + 3.4)$$

Complete these calculations and decide who is correct.

$$578^2 - 312^2 = \dots\dots\dots$$

$$(578 - 312)(578 + 312) = \dots\dots\dots$$

$$8.6^2 - 3.4^2 = \dots\dots\dots$$

$$(8.6 - 3.4)(8.6 + 3.4) = \dots\dots\dots$$

..... is correct [4]

- 9 Helen has some small cubes.
Each cube is 1 cm by 1 cm by 1 cm.
Helen uses all of these small cubes to make this cuboid.

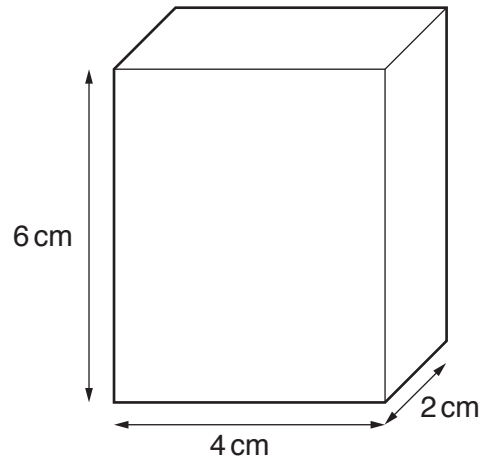

The dimensions of Helen's cuboid are 6 cm by 4 cm by 2 cm.

Helen then uses all these small cubes to make a cuboid with a **square base**.

Find the dimensions of two different cuboids with a square base that Helen could make.

..... cm by cm by cm

..... cm by cm by cm [3]

10 (a) Complete the table for $y = 5x - 3$.

x	0	1	2	3	4
y					

[2]

(b) Draw the graph of $y = 5x - 3$ for values of x from 0 to 4.

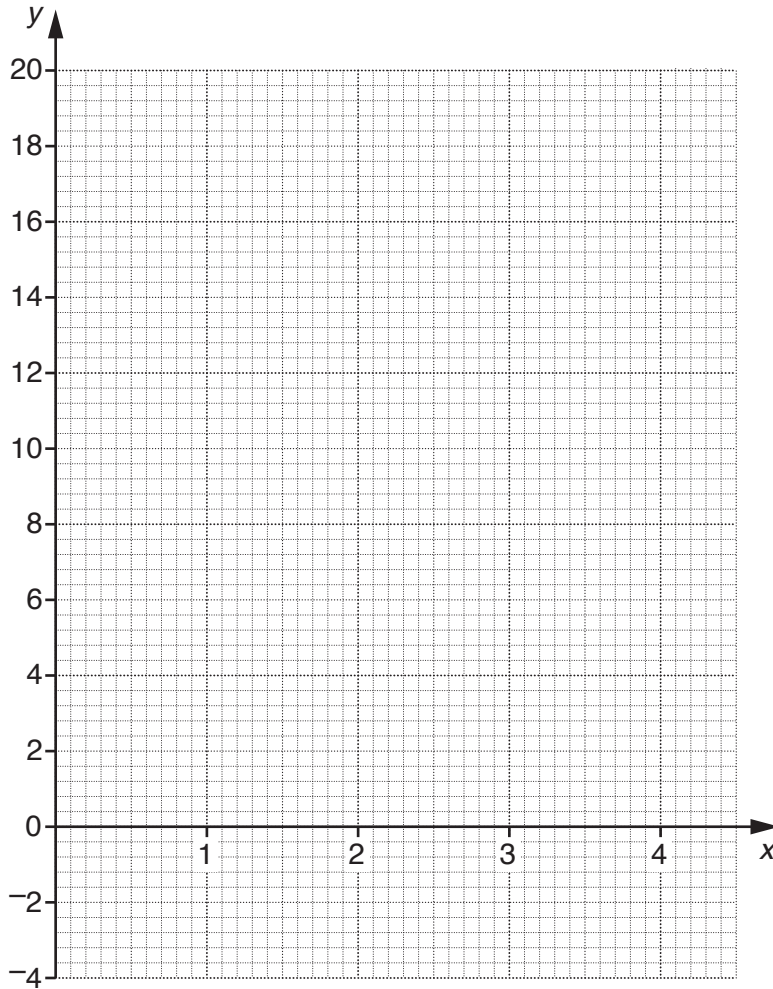

[2]

(c) Solve $5x - 3 = 9$.

(c) [2]

11 The pentagons ABCDE and PQRST are mathematically similar.

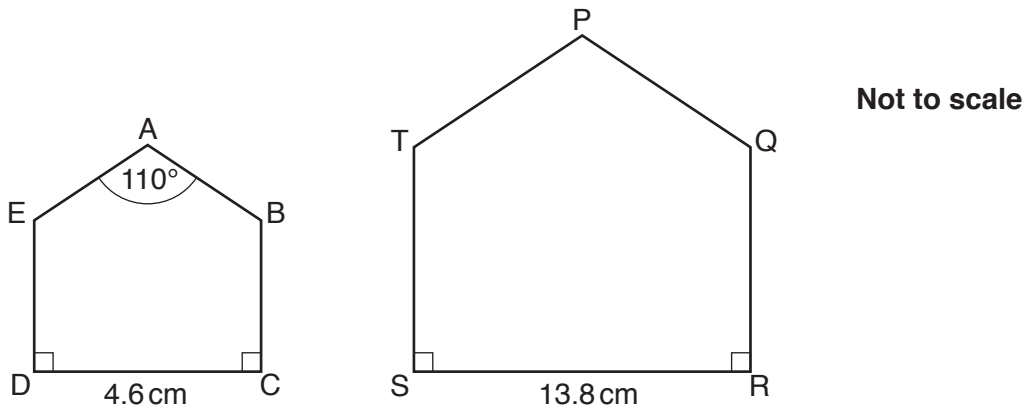

DC = 4.6 cm and SR = 13.8 cm. Angle EAB = 110°.

The perimeter of ABCDE is 18.2 cm.

(a) Find the size of angle TPQ.

(a)° [1]

(b) Find the perimeter of PQRST.

(b) cm [2]

- 12 (a) The angles of this triangle, a , b and c , are measured in degrees.
Angle a is an obtuse angle.

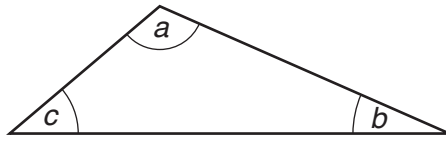

Not to scale

Draw a ring around the inequality that is true for these angles.

$a > b + c$

$a < b + c$

$a + b < c$

$a \leq b + c$

[1]

- (b) This is a different triangle.

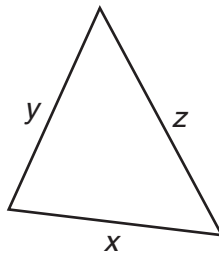

Not to scale

The lengths of the sides, x , y and z , are measured in centimetres.
Draw a ring around the inequality that is true for these lengths.

$x > y + z$

$x < y + z$

$x \geq y + z$

$y > x + z$

[1]

13 Draw a line to match each statement on the left with the way of working it out on the right.

An example has been done for you.

Some of the boxes on the right will not be used.

	0.28×875
Find 30% of 875	0.34×875
	0.3×875
Increase 875 by 34%	
	0.72×875
Increase 875 by 6%	1.34×875
	1.6×875
Decrease 875 by 28%	1.06×875

[3]

- 14 (a) Fill in the missing fractions, decimals and percentages in the table below. Give answers in their simplest forms. The top row has been done for you.

Fraction	Decimal	Percentage
$\frac{1}{4}$	0.25	25%
		30%
$\frac{7}{20}$		
	0.64	

[4]

- (b) Find the missing number.

$$14 \times \boxed{} = 1$$

[1]

- (c) Find a number that is bigger than $\frac{1}{3}$ but smaller than $\frac{1}{2}$.

(c) [2]

16 (a) Share £60 in the ratio 8:7.

(a) £....., £..... [2]

(b) The ratio of red sweets to black sweets in a bag is 3:2.
There are only red sweets and black sweets in the bag.

(i) What fraction of the sweets in the bag are red?

(b)(i) [1]

(ii) Kirsty opens the bag of sweets and eats 5 black sweets.
This leaves only one black sweet in the bag.

What is the ratio of red sweets to black sweets now?

(ii) : [3]

17 (a) Solve.

$$7(x + 2) = 9x - 1$$

(a) [3]

(b) Make t the subject of the following formula.

$$v = u + at$$

(b) [2]

- 18 (a) The shape below is made from a semicircle and a triangle PQR. The triangle is isosceles and right-angled. PQ is the diameter of the semicircle. PQ = 8 cm.

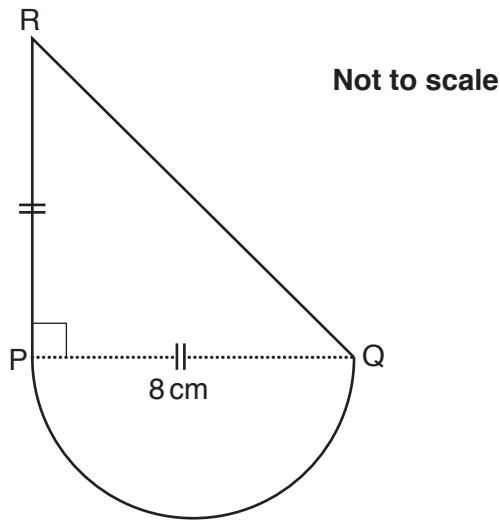

Calculate the area of the shape.

(a) cm² [5]

- (b) The cross-section of a prism has area 81 cm². The volume of the prism is 350 cm³.

Calculate the length of the prism.

(b) cm [2]

ADDITIONAL ANSWER SPACE

If additional space is required, you should use the following lined page(s). The question number(s) must be clearly shown in the margin(s).

A large area of lined paper for writing answers. It features a vertical margin line on the left side and horizontal dotted lines for writing. The lines are evenly spaced and extend across the width of the page.

A large rectangular area with a vertical solid line on the left side and horizontal dotted lines extending across the page, providing a grid for writing answers.



Copyright Information

OCR is committed to seeking permission to reproduce all third-party content that it uses in its assessment materials. OCR has attempted to identify and contact all copyright holders whose work is used in this paper. To avoid the issue of disclosure of answer-related information to candidates, all copyright acknowledgements are reproduced in the OCR Copyright Acknowledgements Booklet. This is produced for each series of examinations and is freely available to download from our public website (www.ocr.org.uk) after the live examination series.

If OCR has unwittingly failed to correctly acknowledge or clear any third-party content in this assessment material, OCR will be happy to correct its mistake at the earliest possible opportunity.

For queries or further information please contact the Copyright Team, First Floor, 9 Hills Road, Cambridge CB2 1GE.

OCR is part of the Cambridge Assessment Group; Cambridge Assessment is the brand name of University of Cambridge Local Examinations Syndicate (UCLES), which is itself a department of the University of Cambridge.