

**ADVANCED GCE
MATHEMATICS**

Mechanics 3

4730

Candidates answer on the answer booklet.

OCR supplied materials:

- 8 page answer booklet (sent with general stationery)
- List of Formulae (MF1)

Other materials required:

- Scientific or graphical calculator

**Monday 24 January 2011
Morning**

Duration: 1 hour 30 minutes



INSTRUCTIONS TO CANDIDATES

- Write your name, centre number and candidate number in the spaces provided on the answer booklet. Please write clearly and in capital letters.
- Use black ink. Pencil may be used for graphs and diagrams only.
- Read each question carefully. Make sure you know what you have to do before starting your answer.
- Answer **all** the questions.
- Do **not** write in the bar codes.
- Give non-exact numerical answers correct to 3 significant figures unless a different degree of accuracy is specified in the question or is clearly appropriate.
- The acceleration due to gravity is denoted by $g \text{ m s}^{-2}$. Unless otherwise instructed, when a numerical value is needed, use $g = 9.8$.
- You are permitted to use a scientific or graphical calculator in this paper.

INFORMATION FOR CANDIDATES

- The number of marks is given in brackets [] at the end of each question or part question.
- **You are reminded of the need for clear presentation in your answers.**
- The total number of marks for this paper is **72**.
- This document consists of **4** pages. Any blank pages are indicated.

1

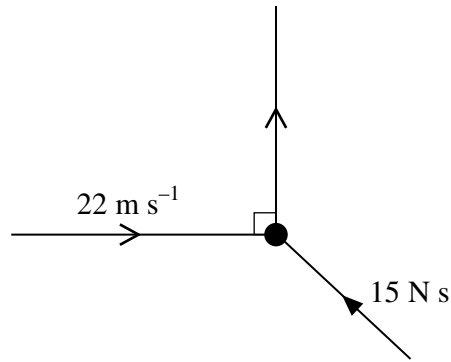

A ball of mass 0.5 kg is moving with speed 22 m s^{-1} in a straight line when it is struck by a bat. The impulse exerted by the bat has magnitude 15 N s and the ball is deflected through an angle of 90° (see diagram). Find

- (i) the direction of the impulse, [3]
 (ii) the speed of the ball immediately after it is struck. [3]

2 A particle of mass 0.4 kg is attached to a fixed point O by a light inextensible string of length 0.5 m . The particle is projected horizontally with speed 6 m s^{-1} from the point 0.5 m vertically below O . The particle moves in a complete circle. Find the tension in the string when

- (i) the string is horizontal,
 (ii) the particle is vertically above O . [6]

3

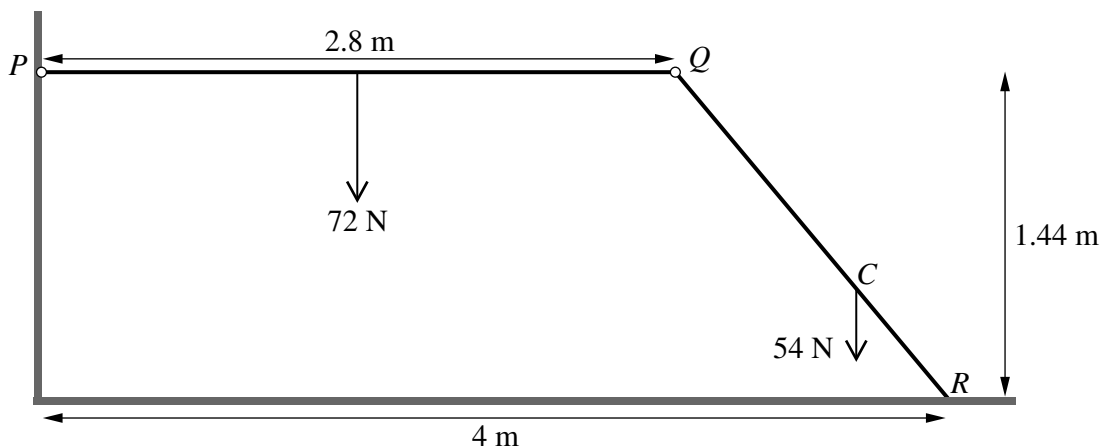

A uniform rod PQ has weight 72 N . A non-uniform rod QR has weight 54 N and its centre of mass is at C , where $QC = 2CR$. The rods are freely jointed to each other at Q . The rod PQ is freely jointed to a fixed point of a vertical wall at P and the rod QR rests on horizontal ground at R . The rod PQ is 2.8 m long and is horizontal. The point R is 1.44 m below the level of PQ and 4 m from the wall (see diagram).

- (i) Find the vertical component of the force exerted by the wall on PQ . [2]
 (ii) Hence show that the normal component of the force exerted by the ground on QR is 90 N . [2]
 (iii) Given that the friction at R is limiting, find the coefficient of friction between the rod QR and the ground. [5]

4

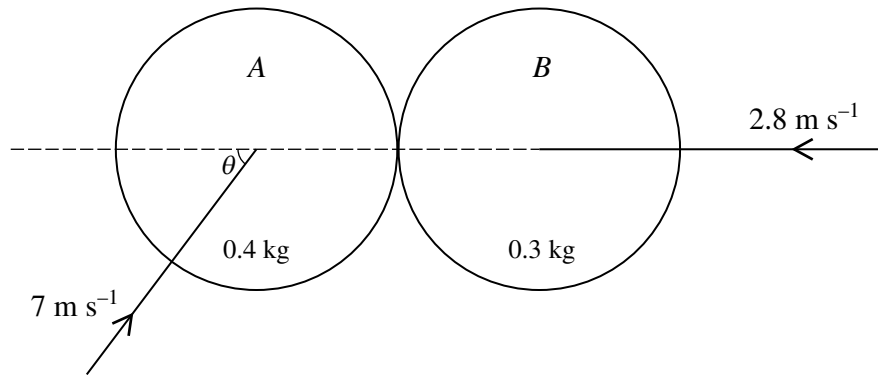

Two uniform smooth spheres A and B of equal radius are moving on a horizontal surface when they collide. A has mass 0.4 kg and B has mass 0.3 kg. Immediately before the collision A is moving with speed 7 m s⁻¹ at an acute angle θ to the line of centres, where $\cos \theta = 0.6$, and B is moving with speed 2.8 m s⁻¹ along the line of centres (see diagram). The coefficient of restitution between the spheres is 0.7 . Find

- (i) the speed of B immediately after the collision, [6]
 (ii) the angle turned through by the direction of motion of A as a result of the collision. [5]

5 A particle P of mass 0.05 kg is suspended from a fixed point O by a light elastic string of natural length 0.5 m and modulus of elasticity 2.45 N.

- (i) Show that the equilibrium position of P is 0.6 m below O . [3]

P is held at rest at a point 0.675 m vertically below O and then released. At time t s after P is released, its downward displacement from the equilibrium position is x m.

- (ii) Show that $\frac{d^2x}{dt^2} = -98x$. [3]

- (iii) Find the value of x and the magnitude and direction of the velocity of P when $t = 0.2$. [7]

[Questions 6 and 7 are printed overleaf.]

6

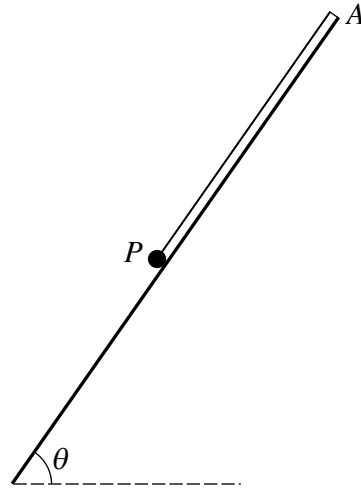

A particle P , of mass 3.5 kg, is in equilibrium suspended from the top A of a smooth slope inclined at an angle θ to the horizontal, where $\sin \theta = \frac{40}{49}$, by an elastic rope of natural length 4 m and modulus of elasticity 112 N (see diagram). Another particle Q , of mass 0.5 kg, is released from rest at A and slides freely downwards until it reaches P and becomes attached to it.

- (i) Find the value of V^2 , where V m s⁻¹ is the speed of Q immediately before it becomes attached to P , and show that the speed of the combined particles, immediately after Q becomes attached to P , is $\frac{1}{2}\sqrt{5}$ m s⁻¹. [6]

The combined particles slide downwards for a distance of X m, before coming instantaneously to rest at B .

- (ii) Show that $28X^2 - 8X - 5 = 0$. [6]

- 7 A particle P of mass 0.2 kg is released from rest at a point O and falls vertically. Air resistance of magnitude $\frac{v^2}{2000}$ N acts upwards on P , where v m s⁻¹ is the velocity of P when it has fallen a distance of x m.

- (i) Show that $\left(\frac{400v}{3920 - v^2}\right) \frac{dv}{dx} = 1$. [2]

- (ii) Find v^2 in terms of x and hence show that $v^2 < 3920$ for all values of x . [7]

- (iii) Find the work done against the air resistance while P is falling, from O , to the point where its downward acceleration is 5.8 m s⁻². [6]

Copyright Information

OCR is committed to seeking permission to reproduce all third-party content that it uses in its assessment materials. OCR has attempted to identify and contact all copyright holders whose work is used in this paper. To avoid the issue of disclosure of answer-related information to candidates, all copyright acknowledgements are reproduced in the OCR Copyright Acknowledgements Booklet. This is produced for each series of examinations and is freely available to download from our public website (www.ocr.org.uk) after the live examination series. If OCR has unwittingly failed to correctly acknowledge or clear any third-party content in this assessment material, OCR will be happy to correct its mistake at the earliest possible opportunity. For queries or further information please contact the Copyright Team, First Floor, 9 Hills Road, Cambridge CB2 1GE.

OCR is part of the Cambridge Assessment Group; Cambridge Assessment is the brand name of University of Cambridge Local Examinations Syndicate (UCLES), which is itself a department of the University of Cambridge.