



Oxford Cambridge and RSA

Monday 13 May 2019 – Morning

AS Level Geology

H014/01 Geology

Time allowed: 2 hours 30 minutes



You must have:

- a ruler (cm/mm)
- a protractor
- a pencil

You may use:

- a scientific or graphical calculator



Please write clearly in black ink. **Do not write in the barcodes.**

Centre number

--	--	--	--	--

Candidate number

--	--	--	--

First name(s)

Last name

INSTRUCTIONS

- Use black ink. You may use an HB pencil for graphs and diagrams.
- Answer **all** the questions.
- Where appropriate, your answers should be supported with working. Marks may be given for a correct method even if the answer is incorrect.
- Write your answer to each question in the space provided. If additional space is required, use the lined page(s) at the end of this booklet. The question number(s) must be clearly shown.

INFORMATION

- The total mark for this paper is **120**.
- The marks for each question are shown in brackets [].
- Quality of extended responses will be assessed in questions marked with an asterisk (*).
- This document consists of **36** pages.

2
Section A

You should spend a maximum of 30 minutes on this section.

Write your answer to each question in the box provided.

Answer all the questions.

The block diagram below shows an ocean ridge. Questions 1 and 2 refer to this diagram.

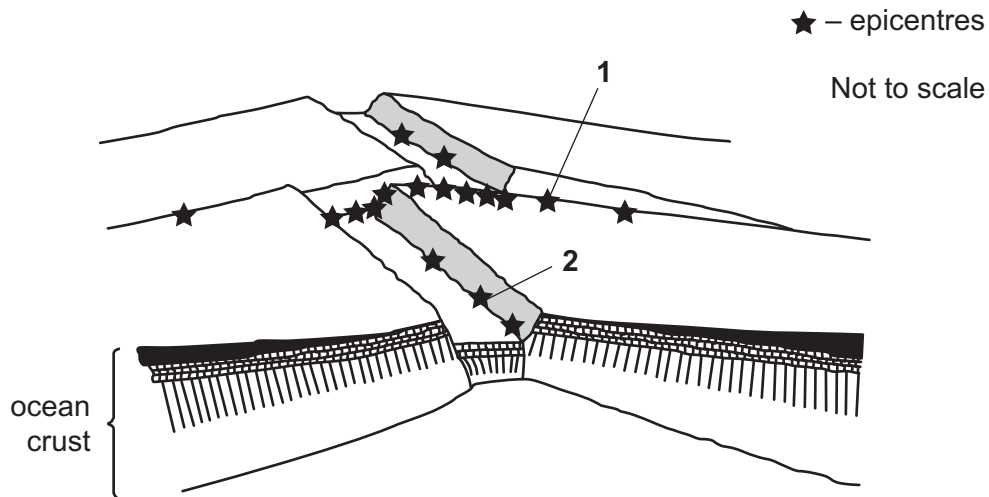

1 Which of the following types of stress has caused the earthquake at position 1?

- A compressive
- B shear
- C tensional
- D compressive and shear

Your answer

[1]

2 Which type of fault, A to D, causes earthquakes at position 2?

- A thrust
- B normal
- C reverse
- D strike-slip

Your answer

[1]

3 The transition described in which of the following options, **A** to **D**, marks the sudden change in chemical composition at 7 km below the ocean floor?

- A crust and mantle
- B upper and lower mantle
- C lithosphere and asthenosphere
- D sheeted dykes and gabbros

Your answer

[1]

4 Not all the weathering processes result in clastic sediments.

Which of the options, **A** to **D**, is the result of chemical weathering?

- A evaporites
- B conglomerates
- C sandstones
- D greywackes

Your answer

[1]

5 The geological column for the Phanerozoic is divided into eras and periods.

Which of the following, **A** to **D**, is a correct statement about the Phanerozoic?

- A The end of the Carboniferous period defines the top of the Palaeozoic.
- B The Mesozoic era contains the Permian, Triassic and Jurassic periods.
- C The Permian period is older than the Devonian.
- D The Silurian period is younger than the Ordovician.

Your answer

[1]

- 6 Deformation in rocks can take place by folding or faulting. Strain that occurs in a short time happens at a high strain rate.

Which of the following conditions, **A** to **D**, are most likely to result in folding?

- A high strain rate and high temperature
- B high confining pressure and low strain rate
- C low temperatures and high strain rate
- D low strain rate and low confining pressure

Your answer

[1]

- 7 Which of the following, **A** to **D**, is **not** standard equipment for conducting Mohs hardness test on a selection of minerals?

- A Bunsen burner
- B copper coin
- C steel file
- D steel nail

Your answer

[1]

- 8 Which of the following, **A** to **D**, is **not** a characteristic of common rock forming minerals?

- A cleavage
- B foliation
- C habit
- D lustre

Your answer

[1]

The thin-section diagram shows a diagnostic texture of an igneous rock. Questions 9 and 10 refer to this diagram.

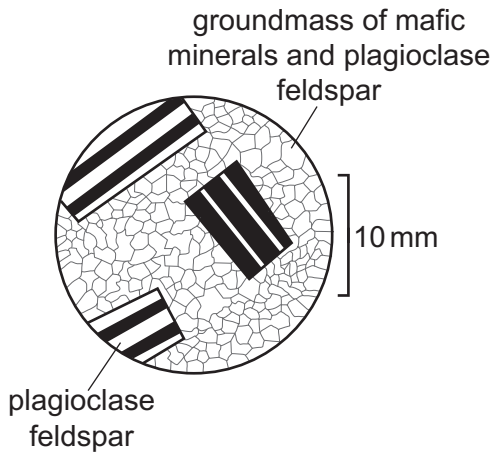

9 Which of the statements, **A** to **D**, correctly describes the texture shown in the diagram?

- A The texture is vesicular.
- B The texture is amygdaloidal.
- C The texture shows flow banding.
- D The texture is porphyritic.

Your answer

[1]

10 Which of the statements, **A** to **D**, most accurately describes the cooling history and tectonic setting of the rock?

- A This dolerite cooled just below the surface.
- B This gabbro cooled close to the surface.
- C This obsidian cooled instantly at the surface.
- D This peridotite cooled at great depth.

Your answer

[1]

- 11 Rock-forming silicate minerals are built up from silicon-oxygen tetrahedra in ways which determine their physical properties.

Which of the options, **A** to **D**, correctly describes a silicate?

- A** Chain silicates have a single cleavage.
- B** Sheet silicates show conchoidal fracture.
- C** Framework silicates have high hardness values.
- D** Sheet silicates have two good cleavages almost at 90° .

Your answer

[1]

- 12 The composition of which of the options, **A** to **D**, is thought to be represented by the composition of iron meteorites?

- A** the Sun
- B** the Earth's core
- C** the Earth's mantle
- D** the Earth's continental crust

Your answer

[1]

- 13 Which of the options, **A** to **D**, is evidence for the nebular hypothesis of the formation of the Solar System?

- A** The composition of meteorites.
- B** The composition of the Earth's Moon.
- C** The Earth's magnetic field.
- D** The direction of rotation of the Sun.

Your answer

[1]

14 Which of the processes, **A** to **D**, is the likely result of a substantial **negative** Bouguer gravity anomaly on a continent?

- A subduction
- B decreased erosion
- C uplift
- D subsidence

Your answer

[1]

15 Which of the following options, **A** to **D**, describes a facies association?

- A all the rocks laid down in an environment of deposition
- B all the sedimentary rocks of similar grain size
- C all the rocks that have been metamorphosed to a similar grade
- D all the rocks deposited within a given range of latitudes

Your answer

[1]

The diagram below shows a graphic log. Questions 16, 17 and 18 refer to this diagram.

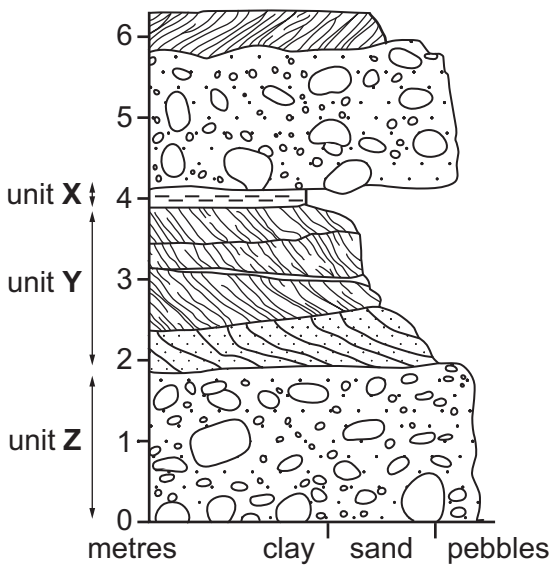

16 Which of the environments, **A** to **D**, would the rocks in the graphic log have been laid down?

- A fluvial
- B glacial
- C desert
- D shallow marine

Your answer

[1]

17 Which of the following rocks best describes unit **X** on the graphic log?

- A conglomerate
- B sandstone
- C greywacke
- D mudstone

Your answer

[1]

18 Unit Z on the graphic log contains pebbles which are scratched.

Which of the options, **A** to **D**, would describe the alignment of the scratches?

- A parallel to the base of the unit
- B parallel to the movement direction
- C at right angles to the movement direction
- D randomly orientated

Your answer

[1]

19 Sediment is partly lithified by the growth of cements.

Which of the following minerals is **least** likely to act as a cement?

- A biotite
- B calcite
- C haematite
- D quartz

Your answer

[1]

20 Which of the statements, **A** to **D**, is evidence for the variations in the Earth's magnetic field?

- A convection in the mantle
- B mantle plumes
- C convection in the core
- D a solid inner core

Your answer

[1]

Section B

Answer **all** the questions.

21 (a) Fig. 21.1 shows a thin-section diagram of a metamorphic rock.

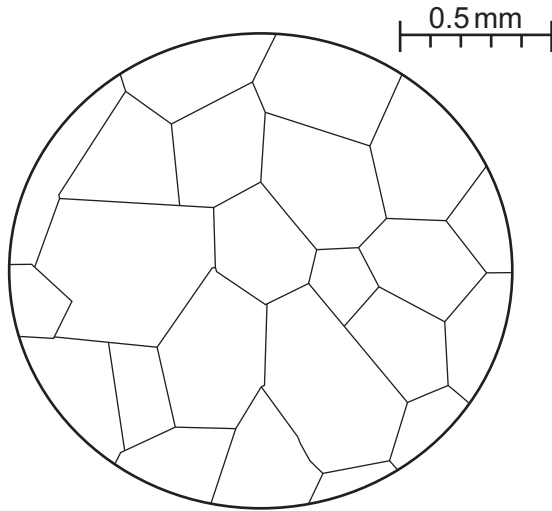

Fig. 21.1

- (i) Using the scale, measure the **average** crystal size.
Give your answer to **2** significant figures.

average crystal size = mm [2]

- (ii) Describe the metamorphic texture shown in Fig. 21.1.

.....
..... [1]

(iii) The thin section was produced from a sample of the rock at position **A** on the map, Fig. 21.2.

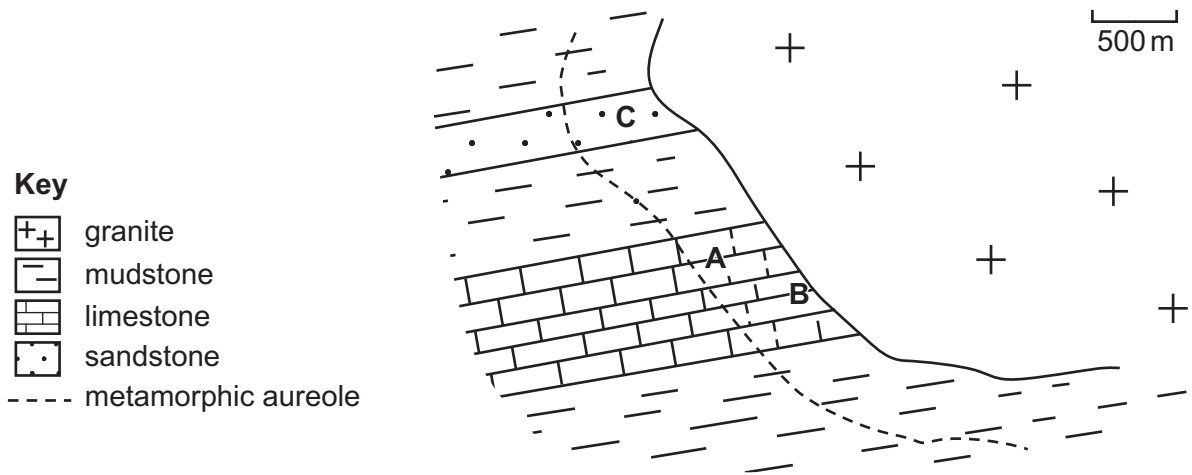

Fig. 21.2

What is the most likely composition of the crystals?

..... [1]

(iv) State and explain **one** difference that would be seen if the thin section had been produced from a rock at position **B**.

.....

 [2]

(b) A rock with similar texture is found at position **C** on Fig. 21.2.

Describe the composition and process of formation of this metamorphic rock.

.....

 [2]

(c) In an area subjected to **regional** metamorphism, distinct changes to an original mudstone can be seen in thin sections as the metamorphic grade increases.

(i) In the circles below sketch and label the minerals that would result from low-grade, medium-grade and high-grade metamorphism. Make sure that the metamorphic minerals are drawn to the correct scale.

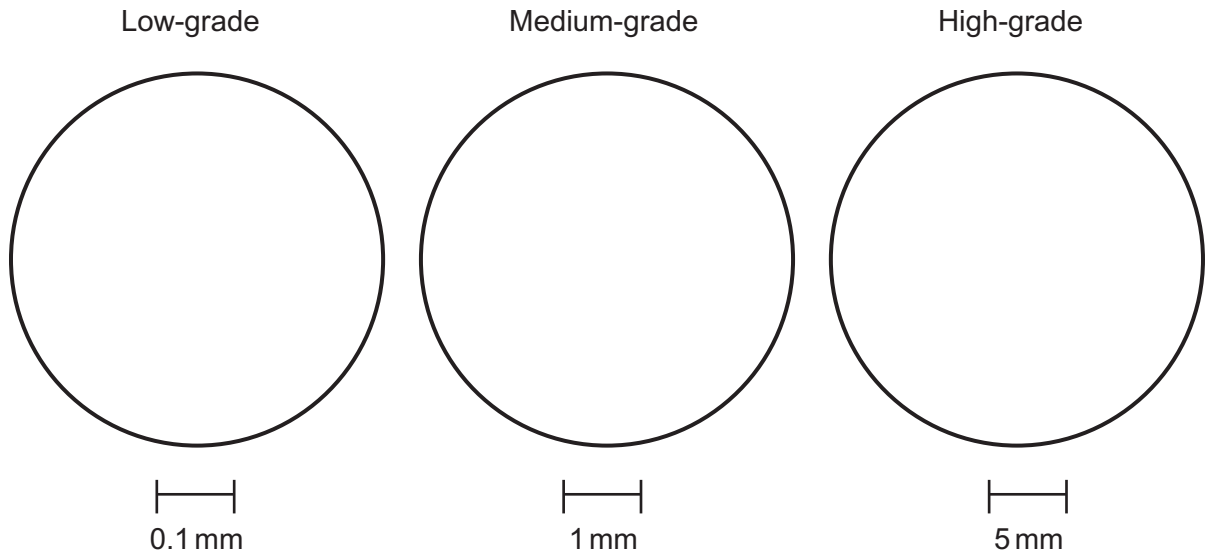

[6]

(ii) On the low-grade diagram draw and label **two** arrows showing the direction of the maximum principal stress. [1]

13
BLANK PAGE

PLEASE DO NOT WRITE ON THIS PAGE

Turn over for the next question

(ii) Plot the results from Fig. 22 as a **cumulative frequency curve** on the graph below.

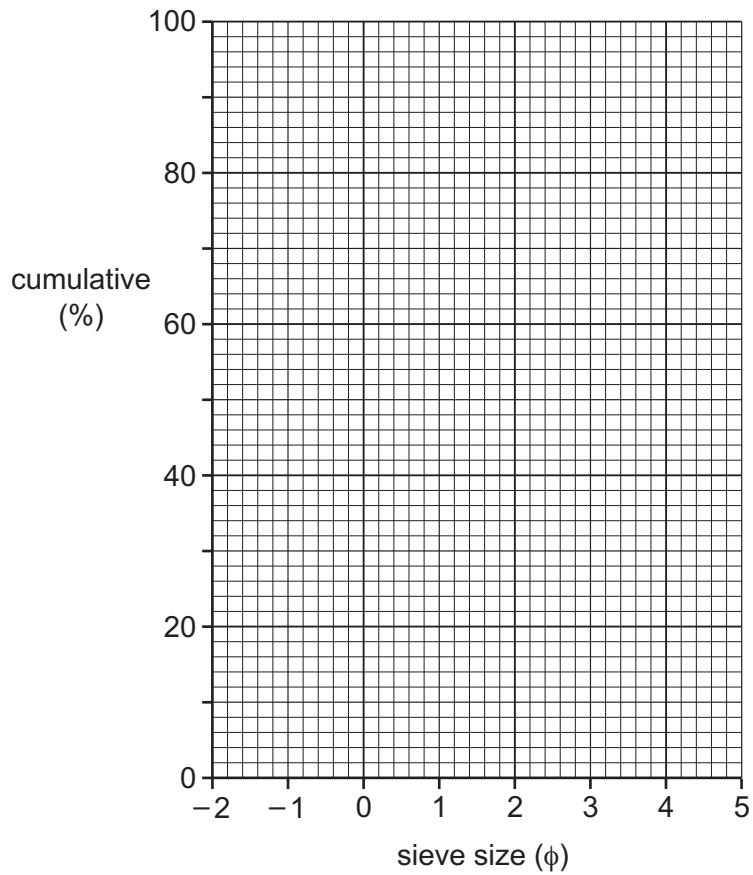

[3]

(c) Calculate the mean grain size of the sediment sample using results taken from your cumulative frequency curve.

Use the formula: $\text{mean grain size} = \frac{\phi_{16} + \phi_{50} + \phi_{84}}{3}$

Give your answer to an appropriate number of significant figures.

mean grain size = [2]

17
BLANK PAGE

PLEASE DO NOT WRITE ON THIS PAGE

Turn over for the next question

23 A student studied an area of folded and faulted rocks, recording the outcrop data along a traverse **W** to **E**. The area is flat-lying and impossible to measure dips and strikes. Only the fault plane can be measured giving an **apparent** dip of 40° to the East.

A map of the area can be seen in Fig. 23.1.

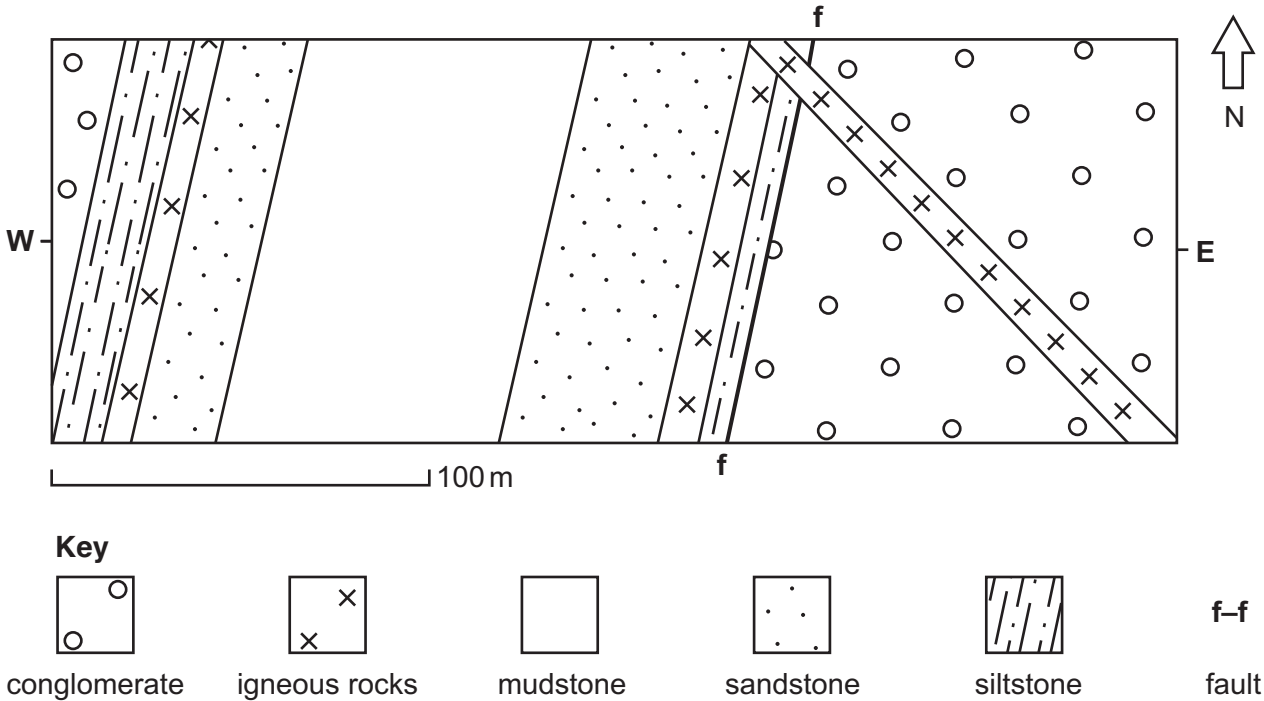

Fig. 23.1

(a) The type of fold can be determined if the relative age of the rocks is known. The mudstone contained fossil **D** and the siltstone contained fossil **E** as shown in Fig. 23.2.

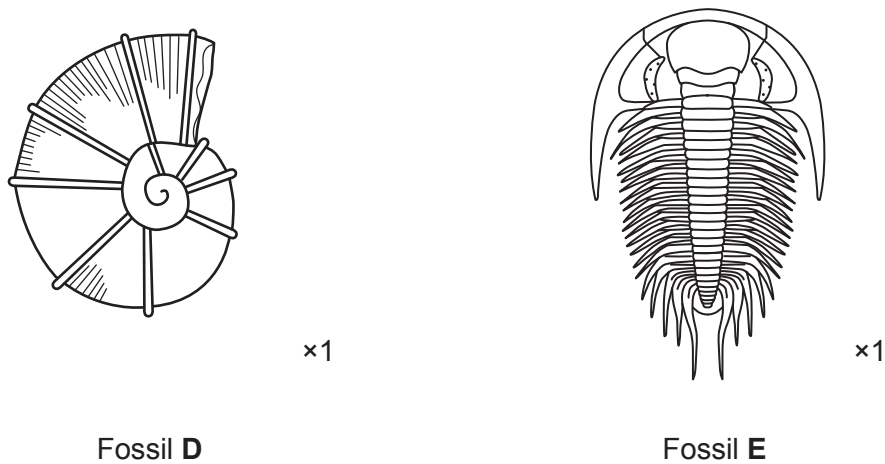

Fig. 23.2

(i) Identify fossils **D** and **E** from Fig. 23.2.

Fossil **D**

Fossil **E**

[1]

- (ii) State the evidence fossils **D** and **E** provide for the relative ages of the mudstone and siltstone.

.....

 [2]

- (iii) Identify the type of fold seen on the map in Fig. 23.1.

.....
 [1]

- (b) (i) Sketch a cross-section diagram between **W** and **E** from Fig. 23.1 in the space below.
 Use the symbols in the map key to show which beds you have drawn.



- (ii) On your diagram in (b)(i), draw arrows on the fault plane to show the relative movement directions of rock on both sides of the fault. [1]

- (iii) What type of fault has affected the geology?

..... [1]

- (iv) There is evidence of fault breccia where the fault (**f-f**) intersects the surface.

Draw and label what would be seen there in the box below.

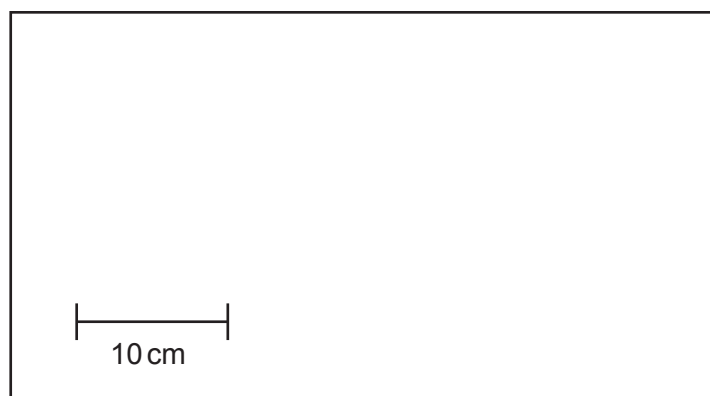

[2]

- 24 (a) The diagram shown in Fig. 24.1 represents two continental areas separated by an ocean. One plate boundary is a subduction zone and the other is passive. The rate of subduction is 2 cm a^{-1} and there is a continent–continent collision in 75 Ma.

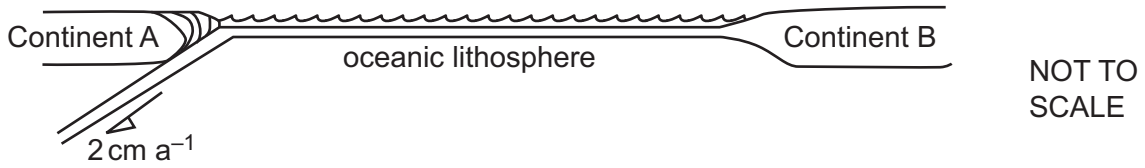

Fig. 24.1

Calculate the width of the ocean **and** describe the tectonic events that will occur.

width of ocean = km

tectonic events.....

.....

[3]

Question 24(b) begins on page 22

(d) (i) The global distribution of geological features is used to construct past plate movement.

Explain how mantle plumes and hot spots can be used to show the rate of recent plate motion.

.....
.....
.....
..... [2]

(ii) Name another method of finding the absolute rate of plate motion.

..... [1]

25
BLANK PAGE

PLEASE DO NOT WRITE ON THIS PAGE

Turn over for the next question

25 Point counting is a method used to find the mineral composition of a thin section. Under a microscope, the mineral under each intersection of a grid is identified and logged to provide an unbiased sample.

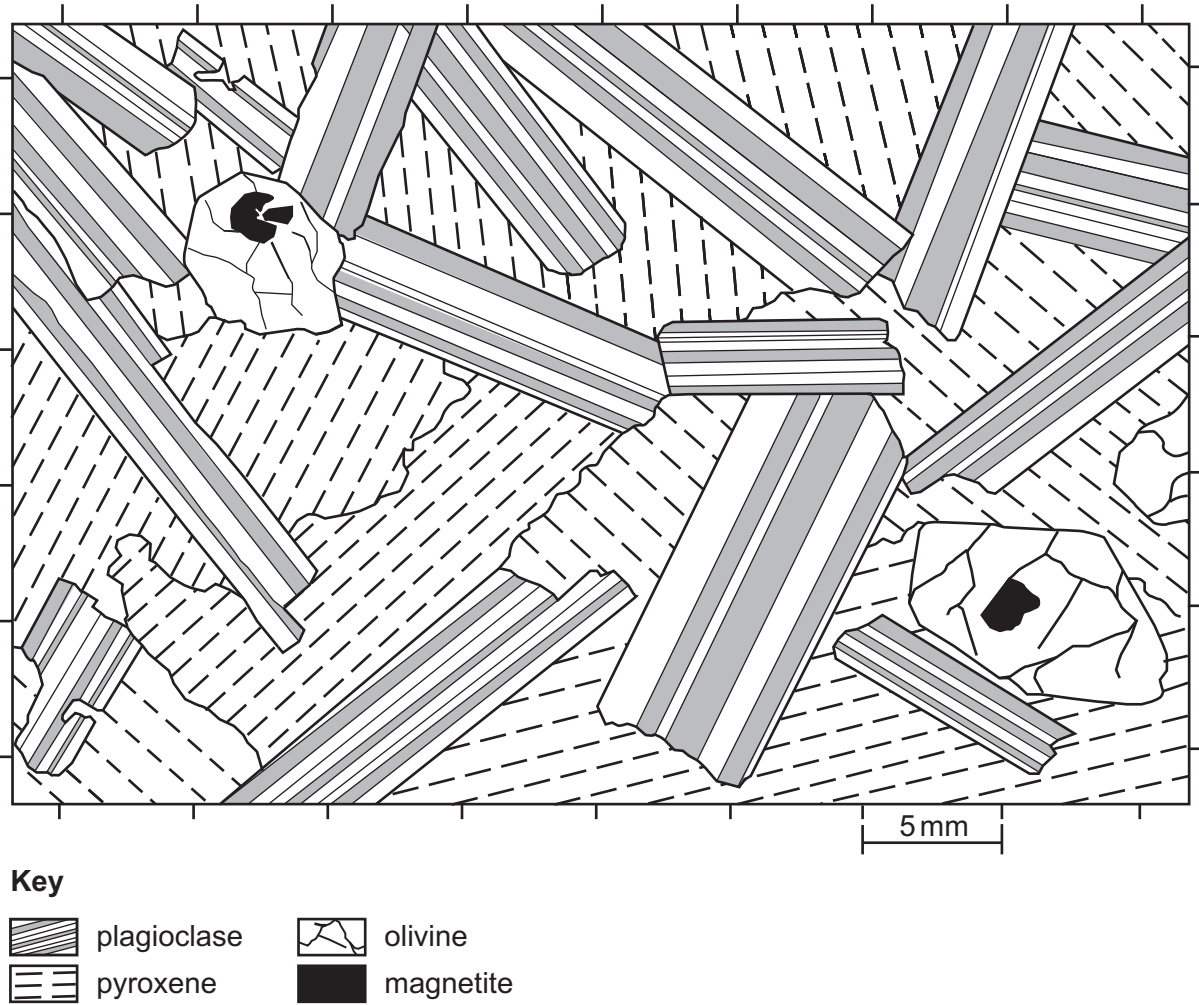

Fig. 25

Fig. 25 above illustrates a thin section. The minerals are identified in the table below.

Mineral	Cleavage	Hardness	Colour
plagioclase	2 at $\sim 90^\circ$	6 – 6.5	black and white
pyroxene	2 at $\sim 90^\circ$	6	yellow/purple
olivine	none	7	green veined with black serpentine
magnetite	none	6	opaque

(a) (i) What is the advantage of using a microscope over a hand lens to identify minerals?

.....

..... [1]

(ii) Which of the minerals in Fig. 25 crystallised first? Explain your reasoning.

mineral

explanation

..... [2]

(iii) What term would best describe the **texture** of this igneous rock?

..... [1]

(b) (i) Using the grid markers around the edge of Fig. 25, draw in gridlines. Identify the mineral beneath each grid intersection and log it on the table below. [2]

Mineral	Tally	Total	%
magnetite			
olivine			
plagioclase			
pyroxene			

(ii) Complete the table above by calculating the percentage of each mineral for this igneous rock.

Give your answers to **2** significant figures. [2]

(iii) Classify the rock composition as either silicic, intermediate, mafic or ultramafic using your measurements of the mineral composition.

..... [1]

(iv) Identify the igneous rock shown in Fig. 25.

..... [1]

(c) (i) Describe **two** possible sources of error in the point counting method.

1

.....

2

..... [2]

(ii) One way of improving the point counting method would be to reduce the size of the grid.

Suggest **two** other ways in which this method could be improved to give a better analysis of the mineral composition of the thin-section diagram in Fig. 25.

1

.....

2

.....

[2]

26 Fossils are used as palaeoenvironmental indicators as well as in relative dating. They may also reveal information on the behaviour of the fossilised organism.

(a) (i) Describe how a trace fossil differs from a body fossil.

.....
..... [1]

(ii) Fig. 26.1 shows trace fossils caused by a trilobite.

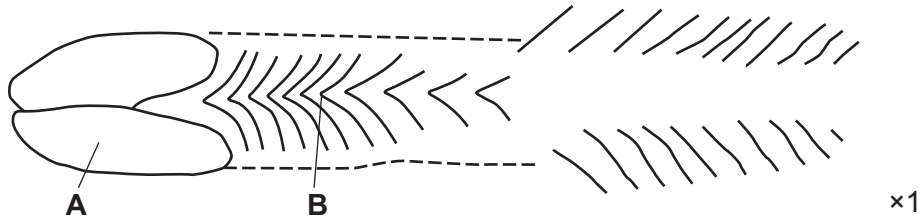

Fig. 26.1

Identify what happened at points **A** and **B** to form the trace fossils.

A.....
B..... [2]

(b) Fig. 26.2 shows two thin-section diagrams, rock Y and rock Z, from two contrasting environments of deposition.

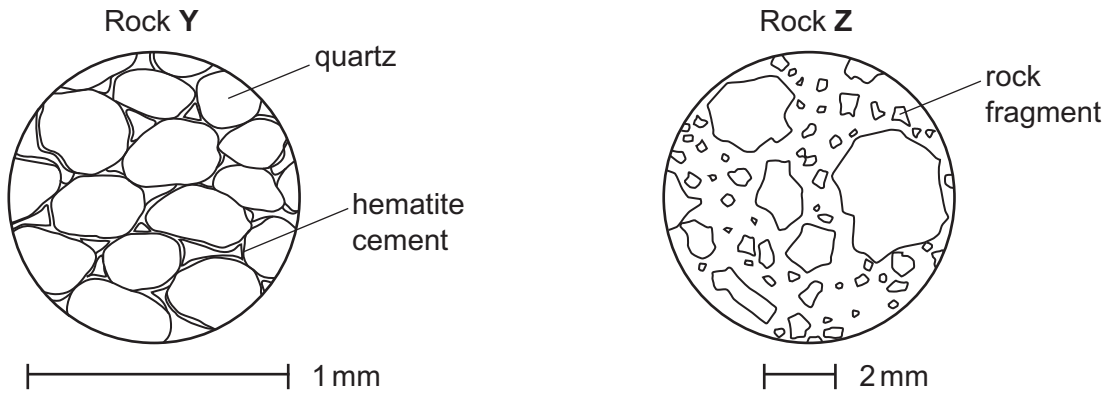

Fig. 26.2

(i) Identify the environments of deposition for the two rocks, Y and Z, shown in Fig. 26.2.

Rock Y.....
 Rock Z..... [2]

(ii) Explain why fossil preservation is unlikely in rocks Y and Z.

.....

 [2]

(c) Fig. 26.3 represents a section through a shallow carbonate sea. Three samples (**P**, **Q** and **R**) have been taken and are described below.

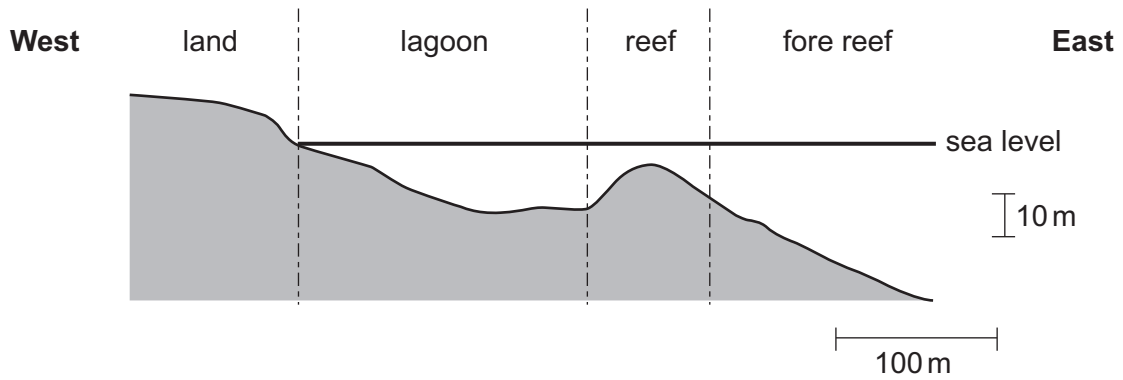

Fig. 26.3

P is composed of spherical calcite grains with concentric layering. Mean grain size 0.5 mm.
Q is composed of calcite mud.
R is composed of fossil fragments with 15% calcite ‘mud’.

(i) Place a tick for each sample in the table to identify the most probable area of deposition.

Sample	land	lagoon	reef	fore-reef
P				
Q				
R				

[1]

(ii) Identify rock **P** and explain how it is formed.

.....

 [2]

(iii) How would rock **R** be classified in the Dunham scheme?

..... [1]

(d) (i) In the oceans deeper than 5 km no calcareous sediment accumulates on the sea floor.

Explain why there are no carbonates at this depth.

.....
.....
.....
..... [2]

(ii) In the oceans distant from the coast, carbonates are deposited on the sea floor forming micritic limestone.

State the characteristics of micritic limestone.

.....
..... [1]

(iii) Within the carbonates described in part (ii), there are often deposits of silica.

Name **and** explain the formation of these unusual rocks.

.....
.....
.....
..... [2]

END OF QUESTION PAPER

ADDITIONAL ANSWER SPACE

If additional space is required, you should use the following lined page(s). The question number(s) must be clearly shown in the margin(s).

A large area of lined paper for writing, consisting of 25 horizontal dotted lines. A solid vertical line runs down the left side of the page, creating a margin. The rest of the page is open for writing.

