



ADVANCED SUBSIDIARY GCE
BIOLOGY
 Cells, Exchange and Transport

F211

Candidates answer on the Question Paper

OCR Supplied Materials:
 None

Other Materials Required:

- Electronic calculator
- Ruler (cm/mm)

Tuesday 12 January 2010
Morning
 Duration: 1 hour



Candidate Forename		Candidate Surname	
--------------------	--	-------------------	--

Centre Number						Candidate Number				
---------------	--	--	--	--	--	------------------	--	--	--	--

INSTRUCTIONS TO CANDIDATES

- Write your name clearly in capital letters, your Centre Number and Candidate Number in the boxes above.
- Use black ink. Pencil may be used for graphs and diagrams only.
- Read each question carefully and make sure that you know what you have to do before starting your answer.
- Answer **all** the questions.
- Do **not** write in the bar codes.
- Write your answer to each question in the space provided, however additional paper may be used if necessary.

INFORMATION FOR CANDIDATES

- The number of marks is given in brackets [] at the end of each question or part question.
- The total number of marks for this paper is **60**.
- You may use an electronic calculator.
- You are advised to show all the steps in any calculations.
- Where you see this icon you will be awarded marks for the quality of written communication in your answer.
- This document consists of **12** pages. Any blank pages are indicated.

Answer **all** the questions.

- 1 (a) State the maximum magnification that can be achieved by a light microscope and a transmission electron microscope.

Select your answers from the list below.

10x 40x 100x 400x 1500x 25 000x 50 000x 500 000x

light microscope x

transmission electron microscope x [2]

- (b) Describe what is meant by the term *resolution*.

.....
.....
.....
..... [2]

- (c) Fig. 1.1 is an electron micrograph of xylem tissue in the stem of a plant.

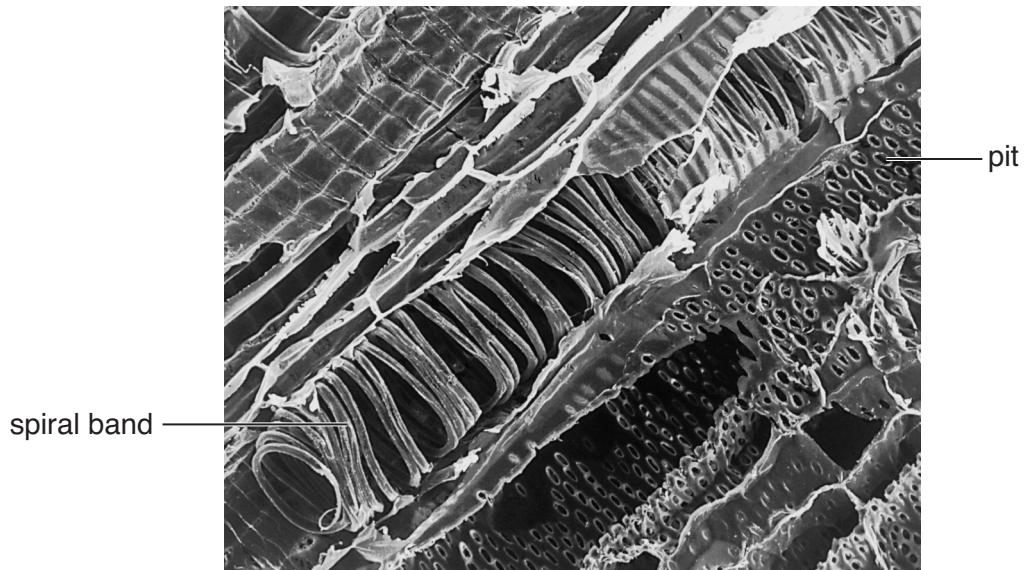

Fig. 1.1

- (i) State **one** function of xylem tissue.

.....
..... [1]

(ii) The spiral band in the xylem vessel shown in Fig. 1.1 contains a substance called lignin. State the function of this spiral band of lignin **and** explain why it is important that the xylem vessel becomes lignified in this way.

.....

.....

.....

.....

.....

.....

.....

.....

..... [3]

(iii) Explain the function of the pits seen in Fig. 1.1.

.....

.....

.....

.....

.....

..... [2]

[Total: 10]

2 (a) (i) Explain what is meant by the term *tissue*.

.....
.....
.....
..... [2]

(ii) Name **one** type of epithelial tissue found in the lungs.

.....
..... [1]

(b) Explain why the lungs can be considered to be an organ.

.....
.....
.....
..... [2]

(c) In the lungs, goblet cells secrete mucus. The mucus is then moved by cilia.

Name **one** cellular structure from the list below that is associated with each of the following functions. You must select a structure once only.

mitochondria ribosome Golgi vesicle centriole nucleus cytoskeleton

(i) release of energy

(ii) movement of cilia

(iii) secrete mucus [3]

[Total: 8]

4 Fig. 4.1 shows a potometer, a piece of apparatus used for estimating the rate of transpiration.

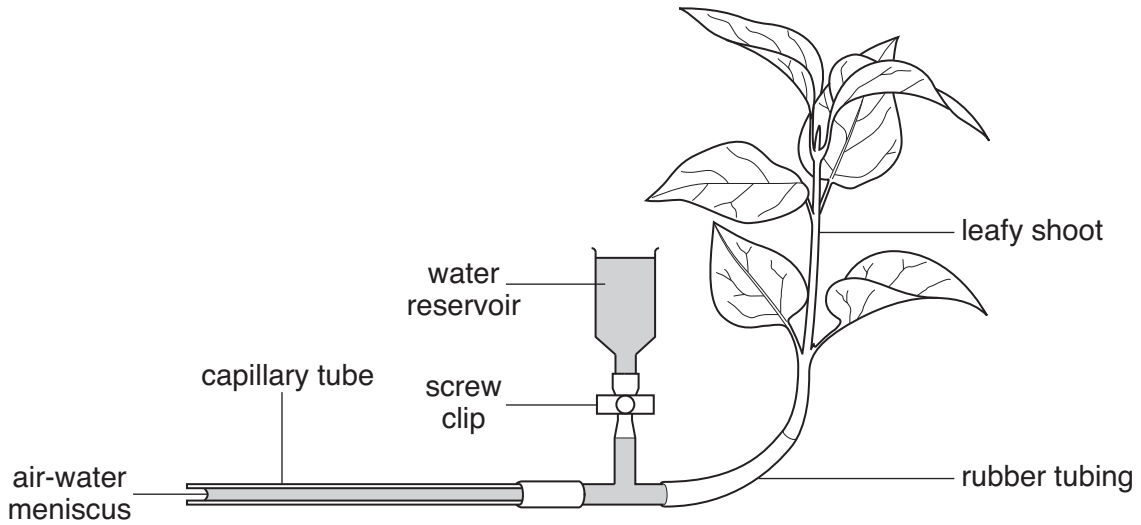

Fig. 4.1

(a) State **one** essential component of the apparatus, not shown in Fig. 4.1, that must be added before any results can be recorded.

..... [1]

(b) Describe **three** steps a student should take when **setting up** the potometer to ensure that the apparatus works correctly.

1

.....

2

.....

3

..... [3]

- (c) A student used the apparatus shown in Fig. 4.1 to investigate how transpiration rates vary during the day. The student placed the potometer on a window ledge in the laboratory and estimated the rate of transpiration four times during the day.

The results are shown in Table 4.1.

Table 4.1

time of day	rate of transpiration (arbitrary units)			
	replicate 1	replicate 2	replicate 3	mean
10.00	32	29	31	30.7
12.00	37	35	38	36.7
14.00	23	26	25	24.7
16.00	25	27	24	

- (i) Calculate the mean value for the rate of transpiration at 16.00 hours.
Give your answer to **one decimal place**.

Answer = [1]

- (ii) Explain why, for each time of the day, the student carried out three replicates to calculate a mean.

.....

 [2]

- (iii) Suggest **two** possible reasons, other than light and temperature, why the rate of transpiration was **lower** in the afternoon than in the morning.

1 [1]

 2
 [2]

- (iv) Explain why the potometer only gives an **estimate** of the rate of transpiration.

.....

 [2]

[Total: 11]

Turn over

5 (a) (i) Fig. 5.1 represents a transverse section of an artery and a vein.

Draw a line to show the relative position of the endothelium of the **vein**.

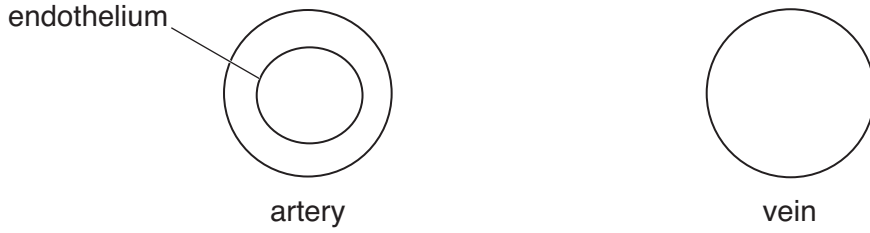

[1]

Fig. 5.1

(ii) State **two other** ways in which the wall of an artery is different from the wall of a vein.

- 1
-
- 2
- [2]

(b) (i) Blood in the arteries has a high hydrostatic pressure.

State how this hydrostatic pressure is generated in the heart.

-
- [1]

(ii) Explain why the hydrostatic pressure of the blood drops as blood moves away from the heart.

-
-
-
- [2]

(iii) Capillaries have walls that are one cell thick.

Fig. 5.2 shows how the hydrostatic pressure of the blood changes as it moves through a capillary.

Fig. 5.2 also shows the water potential of the blood, due largely to the plasma proteins, which tends to move water into the blood.

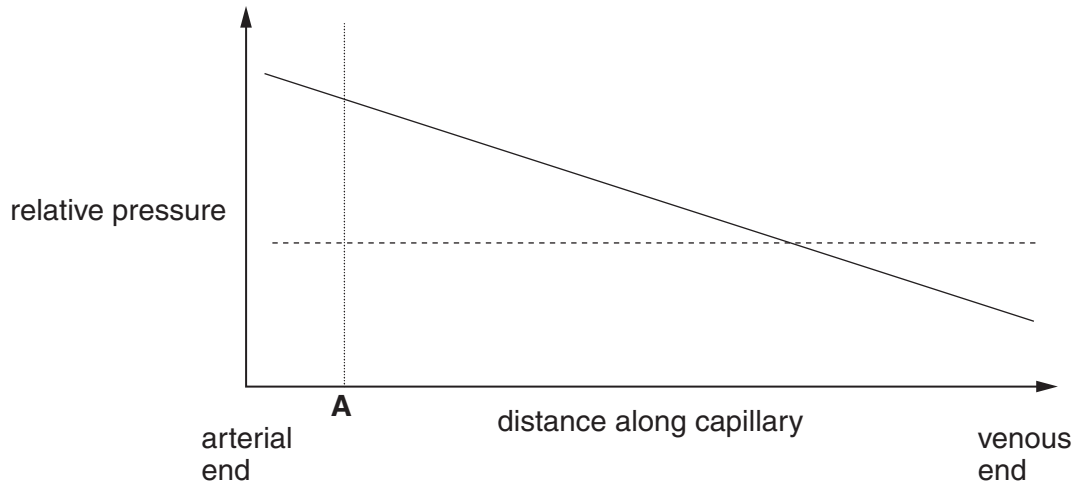

Key:

———— hydrostatic pressure

- - - - - water potential of blood

Fig. 5.2

Describe **and** explain what happens to the blood plasma at point **A** along the capillary in Fig. 5.2.

.....

.....

.....

.....

.....

.....

.....

.....

.....

..... [3]

(c) Carbon dioxide is produced in tissues as a waste product of respiration.

The majority of carbon dioxide is carried as hydrogencarbonate ions (HCO_3^-) in the plasma.

Fig. 5.3 shows the chemical pathway in which carbon dioxide is converted into HCO_3^- in a red blood cell.

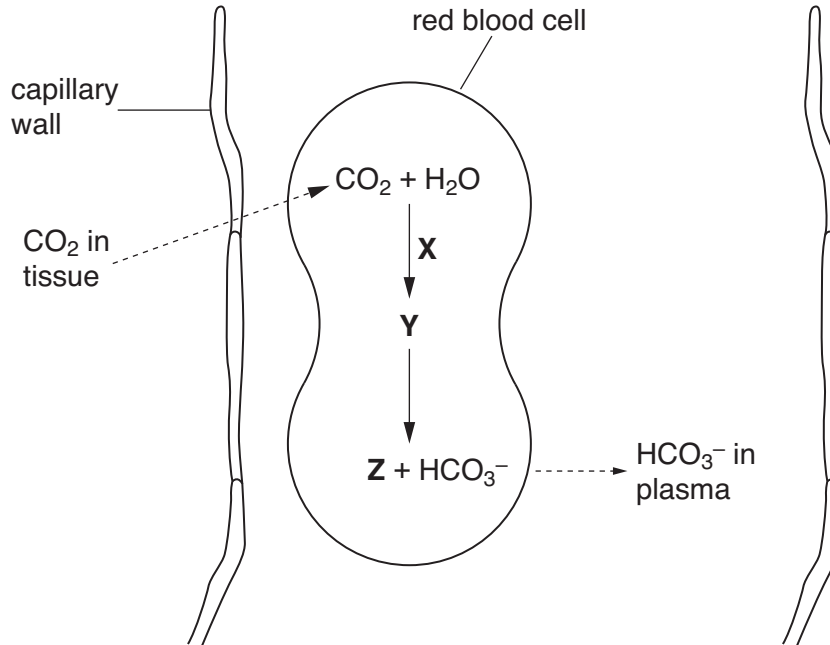

Fig. 5.3

Identify the following:

enzyme **X**

substance **Y**

ion **Z** [3]

[Total: 12]

- 6 Fig. 6.1 is a diagram of a spirometer, a piece of apparatus used to measure some aspects of breathing, such as breathing rate and vital capacity.

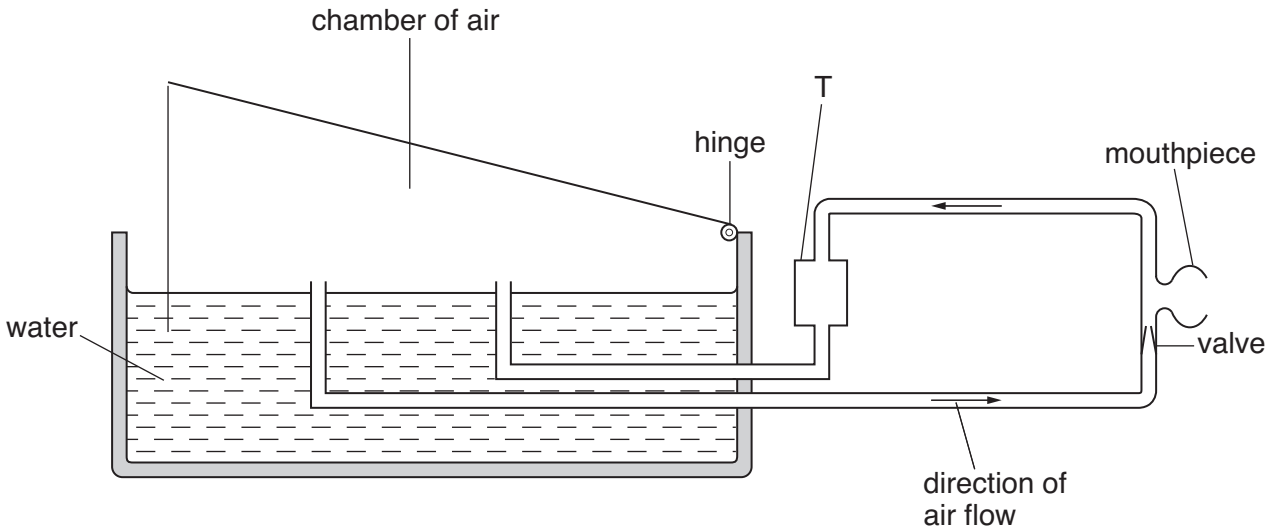

Fig. 6.1

- (a) (i) Outline the mechanism of **inspiration**.



In your answer you should use appropriate technical terms, spelt correctly.

..... [3]

- (ii) A person breathes through the mouthpiece of a spirometer.

State what happens to the air chamber in Fig. 6.1 during **inspiration**.

..... [1]

- (iii) Chamber **T** contains a chemical that absorbs carbon dioxide.

Suggest a chemical that could be used in chamber **T** to absorb carbon dioxide.

..... [1]

QUESTION 6(b) STARTS ON PAGE 12

(b) Explain why a person using the spirometer to measure their vital capacity should wear a nose clip.

.....
.....
.....
..... [2]

(c) State **two** other precautions that should be taken when using a spirometer to measure vital capacity.

1

2

..... [2]

[Total: 9]

END OF QUESTION PAPER



Copyright Information

OCR is committed to seeking permission to reproduce all third-party content that it uses in its assessment materials. OCR has attempted to identify and contact all copyright holders whose work is used in this paper. To avoid the issue of disclosure of answer-related information to candidates, all copyright acknowledgements are reproduced in the OCR Copyright Acknowledgements Booklet. This is produced for each series of examinations, is given to all schools that receive assessment material and is freely available to download from our public website (www.ocr.org.uk) after the live examination series.

If OCR has unwittingly failed to correctly acknowledge or clear any third-party content in this assessment material, OCR will be happy to correct its mistake at the earliest possible opportunity.

For queries or further information please contact the Copyright Team, First Floor, 9 Hills Road, Cambridge CB2 1GE.

OCR is part of the Cambridge Assessment Group; Cambridge Assessment is the brand name of University of Cambridge Local Examinations Syndicate (UCLES), which is itself a department of the University of Cambridge.