



Sample assessment material

Cambridge National in

Engineering Design

**Cambridge OCR Level 1/Level 2 Cambridge National in
Engineering Design**

J822

R040: Design evaluation and modelling

Version 6.0

ocr.org.uk/cambridgenationals

Introduction

This is sample assessment material (SAM). It is an example Cambridge OCR-set assignment that we publish alongside a new specification to help illustrate the intended style and tasks of our set assignments.

We also produce two further specific resources to support you with using this SAM:

- An assessment story where we explain the research we have undertaken during the development of the qualification and how consultation with teachers, students and schools has helped shape our assessment approach.
- A student guide to NEA assignments in which we provide a summary for your students of key points about their Cambridge OCR-set assignments, including the importance of avoiding plagiarism.

Summary of updates

Section	Change	Version	Date
Tasks 1-6 You must/Advice sections	Updated to clarify what students are required to do and what is advisory for each task in the sample assignment.	6.0	June 2026

Copyright information

Cambridge OCR acknowledges the use of the following content:

Page 4: orange speaker/Filip Jedraszak/EyeEm/gettyimages.co.uk;

page 4: portable speaker/George Mdivanian/EyeEm/gettyimages.co.uk;

page 4: blue speaker/Satit Sawtiw/EyeEm/gettyimages.co.uk;

Cambridge OCR-set Assignment

Sample Assessment Material

Cambridge OCR Level 1/Level 2 Cambridge National in Engineering
Design Sample Set Assignment

Unit R040: Design evaluation and modelling

This is a sample set assignment which should only be used for practice.

This assignment **must not** be used for live assessment of students.

The live assignments will be available on our secure website, 'Teach Cambridge'.

The Cambridge OCR administrative codes associated with this unit are:

- unit entry code R040
- certification code J822

The regulated qualification number associated with this unit is:

603/7086/5

Duration: Approximately 10 - 12 hours

ALL OF THIS MATERIAL MAY BE PHOTOCOPIED. Any photocopying will be done under the terms of the Copyright Designs and Patents Act 1988 solely for the purposes of assessment.

Contents

Information for Teachers Using this Assignment.....	3
Scenario for the assignment.....	4
Your tasks and marking grids.....	5
Task 1 – Product analysis.....	5
Task 2 – Product disassembly.....	6
Task 3 – Virtual CAD 3D.....	7
Task 4 – Physical modelling – production planning.....	9
Task 5 – Physical modelling – prototype production.....	11
Task 6 – Physical modelling – evaluation of a prototype.....	13
Marking criteria words.....	14
Teacher Observation Record.....	17
Teacher observation record guidance notes.....	18
Risk Assessment Template.....	19

Information for Teachers

Using this Assignment

You **must**:

- familiarise yourself with the Assessment Guidance relating to the tasks. This is with the unit content in Section 4 of the [Specification](#).
- read and understand **all** the rules and guidance in Section 6 of the [Specification](#) **before** your students complete and you assess the set assignment.
- make sure that completion and assessment fully follows the rules and guidance provided in Section 6 of the [Specification](#).
- give students the [Engineering Design Student guide to NEA assignments](#) before they start the assignment.
- allow students approximately 10-12 guided learning hours (GLH) to complete all tasks.
- complete the [Teacher Observation Record](#) on page 17 for Task 5. You must follow the [guidance](#) given on page 18 when completing it.

You **must not**:

- change or modify this assignment in any way.

Additional Information:

Task 2 requires you to demonstrate the disassembly of an existing portable speaker for students.

The disassembly can be done in front of the class or recorded in advance and shown to the class.

If the disassembly is done in front of the class, it might be useful to record your disassembly of the product so that students can refer back to it.

When completing the demonstration, you **must**:

- disassemble the product in front of the class to show all the relevant components
- advise students to make individual notes during the disassembly demonstration
- advise students to create their own evidence supported with screenshots or images of the disassembly process and the product components
- allow students to inspect the components of the product once disassembled, while completing **Task 2**.

When completing the disassembly demonstration, you **must not**:

- identify or explain the steps taken, including tool and instrument choice, potential hazards and safety considerations
- identify the part names, materials or manufacturing processes of the product.

Scenario for the assignment

Design, evaluation and modelling

Design brief

An audio company produces portable speakers and is looking to develop a new product. They know that many people now use portable speakers at work, in the home or on the move.

Portable speakers include both MP3 and Bluetooth speakers that can be used to listen to the radio, streamed music, or other audio files. They can be situated in a room where an individual or a whole family can listen.

The portable speaker must:

- have a working circuit
- be aesthetically pleasing
- be a simple design that would allow large quantity production
- allow access to the battery so it can be replaced
- have good stability and is free standing
- be constructed from suitable materials for indoor and outdoor use.
- have at least one speaker
- include a switch to turn the speaker on and off



Important Advice:

- Read through all the tasks before you start, so you know what needs to be completed for this assignment.
- Look at the marking criteria grids to see how the tasks will be marked. Your teacher can explain the marking criteria if you need help.
- You will need to use relevant skills/knowledge/understanding from other units you have studied in this qualification.
- You can use the risk assessment template provided for Task 4. Your teacher can give you a Word version to use.

Your tasks and marking grids

Task 1 – Product analysis

Topic Area 1.1 is assessed in this task.

As a design engineer, you have been asked by the audio company to undertake a product analysis of a range of portable speakers to establish the strengths and weaknesses of the designs.

You will need to consider the factors that influence the design of these portable speakers, including how they are manufactured and assembled.

You **must**:

- carry out a comprehensive product analysis of the key features of portable speakers.
- identify the strengths and weaknesses within existing portable speakers.
- compare portable speakers using a customer driven engineering matrix.
- use primary, secondary, or both primary and secondary research to identify the strengths and weaknesses of existing portable speakers.

Total marks for Task 1: 9 marks

Advice

- Use ACCESS FM to help you analyse the portable speakers.
- Use matrix planning, ranking matrices or Quality Function Deployment (QFD) in your comparisons.

Topic Area 1.1: Product Evaluation – Product Analysis

MB1: 1–3 marks	MB2: 4- 6 marks	MB3: 7-9 marks
<p>Produces a basic product analysis of the key features of products using ACCESS FM.</p> <p>Provides a basic description of the strengths and weaknesses of existing products.</p> <p>Basic use of an engineering matrix.</p>	<p>Produces an adequate product analysis of the key features of products using ACCESS FM.</p> <p>Provides an adequate description of the strengths and weaknesses of existing products.</p> <p>Appropriate use of an engineering matrix.</p>	<p>Produces a comprehensive product analysis of the key features of products using ACCESS FM.</p> <p>Provides a comprehensive description of the strengths and weaknesses of existing products.</p> <p>Effective use of an engineering matrix.</p>

If your work does not meet any Mark Band 1 criteria, you will be awarded zero marks for this task.

Task 2 – Product disassembly

Topic Area 1.2 is assessed in this task.

The audio company has reviewed your report and would now like you to undertake further product analysis of an existing portable speaker.

Your **teacher** will disassemble, a portable speaker.

You **must**:

- make your own written notes of the production and construction methods used.
- explain potential hazards, and safety considerations that should be taken when using tools to disassemble the product.
- consider the variety and function of components that are used in the portable speaker.
- establish the most suitable material, production, assembly and manufacturing methods.
- present good quality photographs of each component identified in the disassembly.

Total marks for Task 2: 9 marks

Topic Area 1.2: Product Evaluation – Product Disassembly

MB1: 1–3 marks	MB2: 4-6 marks	MB3: 7-9 marks
Explanation shows a limited understanding of potential hazards and safety considerations when using tools and equipment.	Explanation shows and adequate understanding of potential hazards and safety considerations when using tools and equipment.	Explanation shows a clear understanding of potential hazards and safety considerations when using tools and equipment.
Produces a limited analysis of the components, materials, production methods, assembly, and manufacturing methods used in an engineered product.	Produces an adequate analysis of the components, materials, production methods, assembly, and manufacturing methods used in an engineered product.	Produces a comprehensive analysis of the components, materials, production methods, assembly, and manufacturing methods used in an engineered product.

If your work does not meet any Mark Band 1 criteria, you will be awarded zero marks for this task.

Task 3 – Virtual CAD 3D

Topic Area 2.1 is assessed in this task.

The audio company would now like you to create a 3D model. The audio company has provided you with a technical drawing for the portable speaker, shown in **Figure 1**, to use in this task.

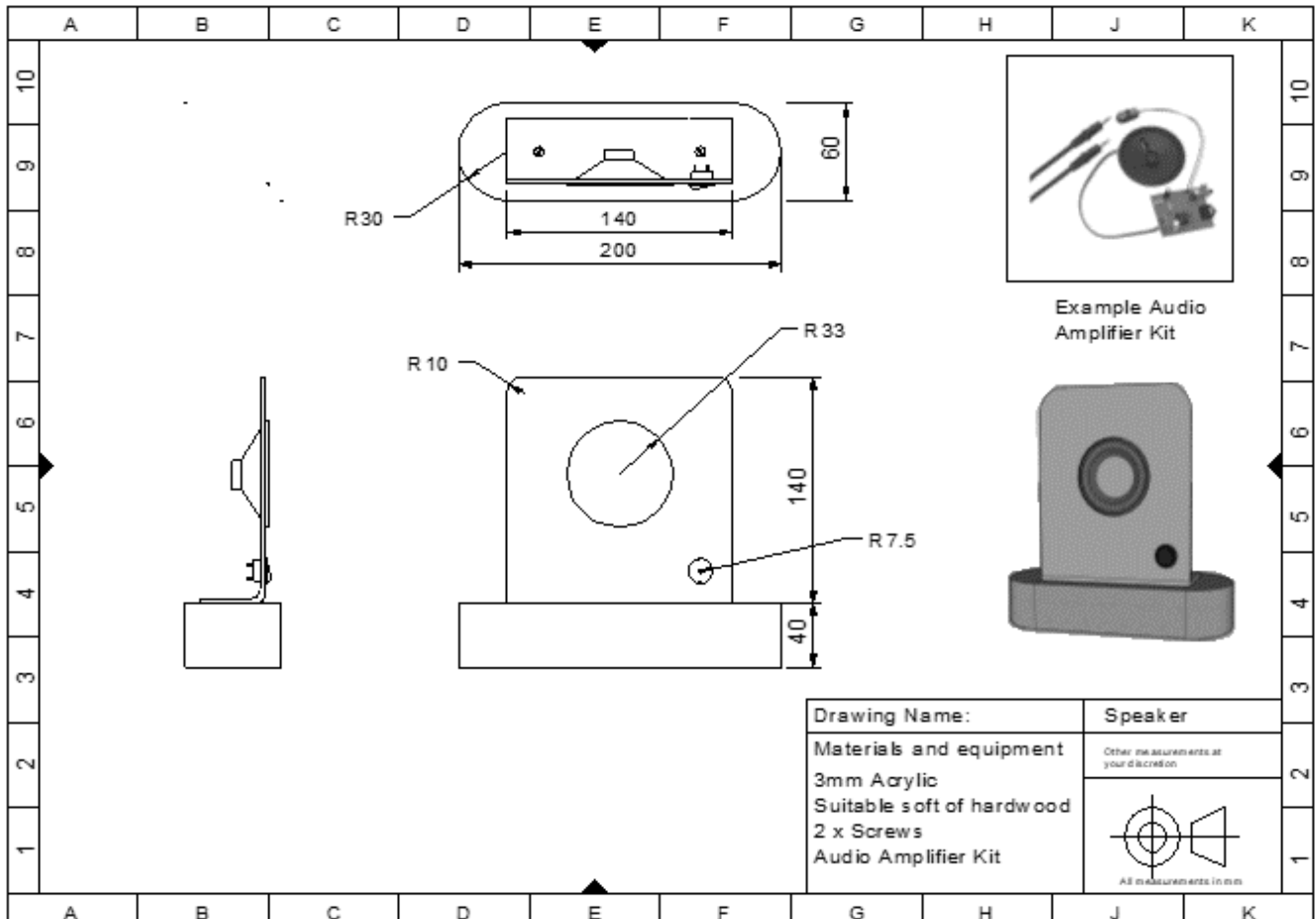

Figure 1

You must:

- use CAD software to produce an accurate virtual 3D model of the portable speaker.
- use CAD software to produce individual components.
- use the mate tools to create a CAD assembly using the individual components.
- use CAD software to demonstrate the model from different viewpoints and simulate the operation of the portable speaker.
- use annotated screenshots to show step-by-step how you have used the CAD software.

Total marks for Task 3: 12 marks

Topic Area 2: Virtual CAD 3D

MB1: 1–4 marks	MB2: 5-8 marks	MB3: 9-12 marks
<p>Produces a basic 3D virtual model using CAD.</p> <p>Produces a simple 3D virtual model consisting of a very limited number of components.</p> <p>Demonstration of complex industry-related CAD activities is dependent upon assistance or help from other sources.</p>	<p>Produces an adequate 3D virtual model using CAD.</p> <p>Produces an adequate 3D virtual model consisting of some mated components.</p> <p>Demonstration of complex industry-related CAD activities is carried out with some assistance or help from other sources.</p>	<p>Produces a comprehensive 3D virtual model using CAD.</p> <p>Produces a complex 3D virtual model consisting of many mated components.</p> <p>Demonstration of complex industry-related CAD activities is carried out independently.</p>

If your work does not meet any Mark Band 1 criteria, you will be awarded zero marks for this task.

Task 4 – Physical modelling – production planning

Topic Area 2.1.2 is assessed in this task.

The audio company is keen to see a prototype of the portable speaker so that it can be tested and evaluated prior to being mass-produced. Create a production plan for the prototype portable speaker based on the technical drawing provided.

You **must**:

- create a detailed plan for manufacturing the prototype portable speaker, identifying the most important production considerations including risk assessment.
- demonstrate knowledge of the safe use of tools and equipment during the manufacture of the prototype portable speaker.

Total marks for Task 4: 6 marks

Advice

- Consider and plan the different stages of manufacturing.
- Carefully consider the risk assessment for each stage of manufacturing.
- Break down the stages of manufacture into manageable chunks and consider how long it will take to undertake each task.
- You can use the template we provide on page 19 for your risk assessment.

Material choice

- The portable speaker can be **modelled** using either:
 - cardboard
 - modelling foam
 - materials including acrylic, timber, metal
 - manufactured board
 - or a combination of these materials.

An example of a mono amplifier kit that could be used during the manufacture of the portable speaker is shown in **Figure 2**.

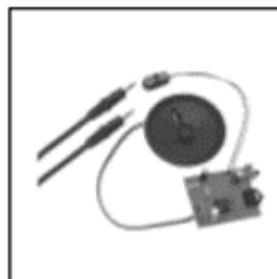

Figure 2

Topic Area 2: Physical modelling – Production Planning

MB1: 1–2 marks	MB2: 3-4 marks	MB3: 5-6 marks
<p>A basic description of the planning stages to be used in the manufacturing of the prototype.</p> <p>Shows limited understanding of safety considerations.</p>	<p>An adequate description of the planning stages to be used in the manufacturing of the prototype.</p> <p>Shows some understanding of safety considerations.</p>	<p>A comprehensive description of the planning stages to be used in the manufacturing of the prototype.</p> <p>Shows a detailed understanding of safety considerations.</p>

If your work does not meet any Mark Band 1 criteria, you will be awarded zero marks for this task.

Task 5 – Physical modelling – prototype production

Topic Area 2.1.2 is assessed in this task.

Use your production plan to create a model of your prototype.

There are aspects of your production plan that you do not need to take forward into the manufacture of your prototype. These include:

- installation of a mono amplifier and speaker

You must:

- use your production plan to manufacture the prototype portable speaker.
- select and use appropriate tools and materials to produce the portable speaker.
- consider your risk assessment and apply safe working practices.
- record all the key stages of making the prototype.
- ask your teacher to complete a Teacher Observation Record for this task.

Total marks for Task 5: 18 marks

Advice

- Ensure you take photographs during each stage of the manufacture of the portable speaker.
- You could keep a “Making Diary” to record all the key stages of making the prototype.
- Ensure you wear appropriate PPE whilst undertaking practical work in line with your risk assessment.
- Follow your manufacturing plan to ensure you manufacture an accurate portable speaker.

Topic Area 2: Physical Modelling – Prototype Production

MB1: 1–6 marks	MB2: 7-12 marks	MB3: 13-18 marks
<p>Dependent upon prompts to use PPE equipment when working with tools, machines, materials, chemicals, finishes and solvents.</p> <p>Use tools and processes with limited effectiveness to produce and assemble an outcome that partly meets the production plan. The prototype will be incomplete.</p> <p>Produces a limited record of the key stages of making the prototype.</p>	<p>Requires some prompting to use appropriate PPE when working with tools, machines, materials, chemicals, finishes and solvents.</p> <p>Use tools and processes with some effectiveness to produce and assemble an outcome that mostly meets the production plan. The prototype will be mostly complete.</p> <p>Produces an adequate record of most of the key stages of making the prototype.</p>	<p>Independently uses appropriate PPE when working with tools, machines, materials, chemicals, finishes and solvents.</p> <p>Use tools and processes effectively to produce and assemble an outcome that is of a high quality, accurate and fully meets the production plan. The prototype will be fully complete.</p> <p>Produces a detailed and accurate record of the key stages of making the prototype.</p>

If your work does not meet any Mark Band 1 criteria, you will be awarded zero marks for this task.

Task 6 – Physical modelling – evaluation of a prototype

Topic Area 2.1.2 is assessed in this task.

Before providing the audio company with your model, you are required to evaluate the prototype to identify any further improvement that could be made to the design.

You **must**:

- evaluate the final prototype against the product specification.
- consider ways that the prototype could be improved.

Total marks for Task 6: 6 marks

Advice

- Explain and sketch your suggestions for ways to improve your portable speaker.

Topic Area 2: Physical Modelling – Evaluation of a Prototype

MB1: 1–2 marks	MB2: 3-4 marks	MB3: 5-6 marks
Produces a basic evaluation of the prototype outcome against the product specification.	Produces an adequate evaluation of the prototype outcome against the product specification.	Produces a comprehensive evaluation of the prototype outcome against the product specification.
Provides limited potential improvements. No justification is provided.	Provides some potential improvements, with justification.	Provides detailed potential improvements with justification.

If your work does not meet any Mark Band 1 criteria, you will be awarded zero marks for this task.

Marking criteria words

The tables below show the command words that will be used in the NEA Marking Criteria grids. They explain the type of evidence that you should expect to see to meet each descriptor word.

Mark Band (MB1) Words:

Word	Meaning
Basic	<ul style="list-style-type: none"> • Work includes the minimum required. It is a starting point but is simplistic and not developed. • Understanding and skills are applied in a way that partly achieves the wanted or intended result, but it would not be useable without further input or work.
Brief/Briefly	<ul style="list-style-type: none"> • Work includes a small number of relevant facts or concepts but lacks detail, contextualisation or examples.
Dependent	<ul style="list-style-type: none"> • The student can perform a task when given regular assistance or help
Few	<ul style="list-style-type: none"> • Work produced is restricted or narrow. It includes less than half of the information or examples expected for a full response.
Inefficient	<ul style="list-style-type: none"> • Outputs are produced but with great expense or effort because of poor organisation or design and not making the best use of available resources.
Limited	<ul style="list-style-type: none"> • Work produced is restricted in range or scope and includes only some of the information required. It evidences partial rather than full understanding. • Work produced is a starting point rather than a developed process, concept or output.
Minimal	<ul style="list-style-type: none"> • Includes very little in amount or quantity required.
Simple	<ul style="list-style-type: none"> • Includes a small number of relevant parts, which are not related to each other.
Superficial	<ul style="list-style-type: none"> • Work completed lacks depth and detail.

Mark Band (MB2) Words:

Word	Meaning
Adequate(ly)	<ul style="list-style-type: none"> • Work includes the appropriate number of relevant facts or concepts but does not include the full detail, contextualisation or examples.
Assisted	<ul style="list-style-type: none"> • The student can perform a task with occasional assistance or help.
Part(ly)/Partial	<ul style="list-style-type: none"> • To some extent but not completely. • Work produced is inclusive in range and scope. It evidences a mainly developed application of understanding, performance or output needed. • Work produced results in a process, concept or output that would be useable for its purpose.
Some	<ul style="list-style-type: none"> • Work produced is inclusive but not fully comprehensive. It includes over half the information or examples expected for a full response.
Sound	<ul style="list-style-type: none"> • Valid, logical, shows the student has secured most of the relevant understanding, but points or performance are not fully developed. • Applies understanding and skills to produce the wanted or intended result in a way that would be useable.

Mark Band (MB3) Words:

Word	Meaning
Accurate(ly)	<ul style="list-style-type: none"> Acting or performing with care and precision. Correct in all details.
All	<ul style="list-style-type: none"> Work produced is fully comprehensive and wide-ranging. It includes almost all, or all the information or examples expected for a full response.
Clear(ly)	<ul style="list-style-type: none"> Focused and accurately expressed, without ambiguity.
Complex	<ul style="list-style-type: none"> Includes many relevant parts, all of which relate to each other logically.
Comprehensive(ly)	<ul style="list-style-type: none"> The work produced is complete and includes everything required to show depth and breadth of understanding. Applies the understanding and skills needed to successfully produce the wanted or intended result in a way that would be fully fit-for-purpose.
Consistent(ly)	<ul style="list-style-type: none"> A level of performance which does not vary in quality over time.
Critical	<ul style="list-style-type: none"> Objective analysis and evaluation in order to form: a judgement, evaluation of the evidence or effective trouble shooting/fault finding.
Detailed	<ul style="list-style-type: none"> Gives point by point consideration of all the key information.
Effective	<ul style="list-style-type: none"> Applies the skills required to the task and is successful in producing the desired or intended result. The work produced is effective in relation to a brief.
Efficient	<ul style="list-style-type: none"> Able to produce results or outputs with the minimum expense or effort, because of good organisation or design and making the best use of available resources.
Full(y)	<ul style="list-style-type: none"> Work produced is comprehensive in range and scope. It evidences a fully developed application of understanding, performance or output needed. Work produced results in a process, concept or output that would be fully fit-for-purpose.
Independent(ly)	<ul style="list-style-type: none"> The student can perform a task without assistance or reliance on others
Justify/Justified	<ul style="list-style-type: none"> The reasons for doing something are explained in full.
Most(ly)	<ul style="list-style-type: none"> Includes nearly all of what is expected to be included.
Wide (ranging)	<ul style="list-style-type: none"> Includes many relevant details, examples or contexts; all of which are fully detailed, contextualised or exemplified.

Teacher Observation Record

Please read the **guidance notes** on the following page before completing this form.

Student name:	
Qualification:	Cambridge OCR Level 1/Level 2 Cambridge National in Engineering Design
Unit number and title:	Unit number: R040
	Unit title: Design evaluation and modelling
Activity observed:	Task title: Physical modelling – prototype production
	Task number: 5
Date activity completed:	
Additional evidence attached:	

TEACHER SECTION:	
How did the student complete the activity? Your response must provide details of what the student did and how this relates to the relevant marking criteria.	
STUDENT SECTION:	
I agree with my teacher's description of how I completed this activity.	Yes <input type="checkbox"/>
Additional student comments:	
Student signature	Date: (DD/MM/YYYY)
Teacher name:	
Teacher signature:	Date: (DD/MM/YYYY)

Teacher observation record guidance notes

The class teacher and student being observed are responsible for completing this form.

The Teacher Observation Record is used by the teacher to detail their observation of a student completing an activity. In order to provide sufficient evidence, the completed form must give contextualised details of what the student did and how this relates to the marking criteria. Simply providing statements from the marking criteria is not acceptable. The evidence provided must be individual to the student.

The Teacher Observation Record is also used to show that the student agrees with the teacher's assessment of this activity.

The information given by the teacher must be shared with the student for the student to agree, or otherwise. If the student does not agree with the teacher's comments and links to the marking criteria, they must have the chance to talk about these further with the teacher to reach an agreed outcome **before** the work is submitted for moderation.

Both the teacher and student must sign and date the form to provide evidence of this agreement.

Additional evidence of the student completing the activity must also be provided with the form. The types of additional evidence that are acceptable are detailed in Tasks 2 and 5.

Teacher observation records must:

- describe what the teacher observed the student doing
- include how well the activity was completed and the reasons for this evaluation
- include confirmation from the student that they agree with the comments and reasons
- be accompanied by additional evidence as required in Tasks 2 and 5.

Teacher observation records must not:

- be a simple repeat of the grading criteria
- be completed by anyone but the teacher observing the activity and the student completing the activity
- be written by the student for the teacher to sign
- contain just a list of skills
- be used to evidence the achievement of a whole unit or task in isolation.

Risk Assessment Template

Risk assessment for _____

The Potential Hazards
Risks
Control Measures

Tell us what you think

Your feedback plays an important role in how we develop, market, support and resource qualifications now and into the future. We want you and your students to enjoy and get the best out of our qualifications and resources, but to do that we need your honest opinions to tell us whether we're on the right track or not.

You can email your thoughts to support@ocr.org.uk or visit our [feedback page](#) to learn more about how you can help us improve our qualifications.



Designing and testing in [collaboration with teachers](#) and students



Helping young people develop an [ethical view of the world](#)



Equality, diversity, inclusion and belonging (EDIB) are [part of everything we do](#)

Contact the team at:

 **01223 553998**

 **ocr.org.uk**

To stay up to date with all the relevant news about our qualifications, register for email updates at ocr.org.uk/updates

Visit our Online Support Centre at support.ocr.org.uk

Sign up for [Teach Cambridge](#) to access your planning, teaching and assessment support material.



Cambridge OCR is part of Cambridge University Press & Assessment, a department of the University of Cambridge.

Cambridge OCR is a Company Limited by Guarantee and an exempt charity. Registered in England.

Registered office: The Triangle Building, Shaftesbury Road, Cambridge, CB2 8EA. Registered company number: 3484466.

We operate academic and vocational qualifications regulated by Ofqual, Qualifications Wales and CCEA as listed in their qualifications registers.

We are committed to providing a fully accessible experience across all our products, platforms, and websites. Find out more about our [accessibility standards](#).

© Cambridge OCR 2026. All rights reserved. We retain the copyright on all our publications. However, our registered centres are permitted to copy and distribute our material for their own internal use, in line with any specific restrictions detailed in the publication. Find out more about our [copyright policies](#).

We update our publications regularly so please check you have the most up-to-date version.

We cannot be held responsible for the persistence or accuracy of URLs for external or third-party internet websites referred to in this publication and do not guarantee that any content on such websites is, or will remain, accurate or appropriate.

When we update our specifications, you'll see a new version number and a summary of the changes. While we do our best to reflect these changes in all associated resources on [Teach Cambridge](#), if you notice any discrepancies, please refer to the latest specification on our website and [let us know](#).

Our resources do not represent any teaching method we expect you to use. We cannot be held responsible for any errors or omissions in our resources.