



Oxford Cambridge and RSA

Tuesday 12 January 2021 – Morning

Level 1/2 Cambridge National in Principles in Engineering and Engineering Business

R101/01 Engineering principles

Time allowed: 1 hour



You must have:

- a scientific or graphical calculator
- a ruler (cm/mm)



Please write clearly in black ink. **Do not write in the barcodes.**

Centre number

--	--	--	--	--

Candidate number

--	--	--	--

First name(s)

Last name

INSTRUCTIONS

- Use black ink. You can use an HB pencil, but only for graphs and diagrams.
- Write your answer to each question in the space provided. If you need extra space use the lined pages at the end of this booklet. The question numbers must be clearly shown.
- Answer **all** the questions.

INFORMATION

- The total mark for this paper is **60**.
- The marks for each question are shown in brackets [].
- Quality of written communication will be assessed in questions marked with an asterisk (*).
- This document has **12** pages.

ADVICE

- Read each question carefully before you start your answer.

Answer **all** the questions.

1 (a) Fig. 1 shows a lighting circuit.

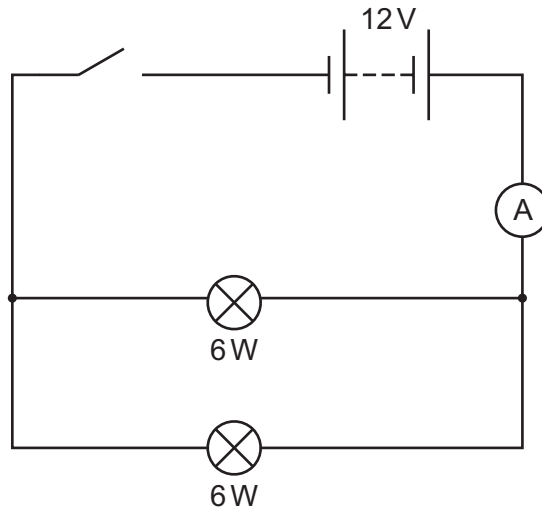

Fig. 1

(i) Draw on Fig. 1 the symbol for a voltmeter, in the correct position to measure the potential difference across the switch. [2]

(ii) Give the reading that would show on the voltmeter when:

the switch is **open**

.....

the switch is **closed**.

.....

[2]

(iii) State the type of circuit arrangement for the lamps in Fig. 1.

.....

[1]

(iv) Draw an arrow on Fig. 1 to show the direction of travel for the current flow.

[1]

(b) Complete the statement using the correct terms from the list below. Not all the terms will be used.

parallel voltage current the same series different

The sum of the in each branch of the circuit equals the current leaving the power supply. The is across all components. [4]

2 Fig. 2 shows a wheelbarrow.

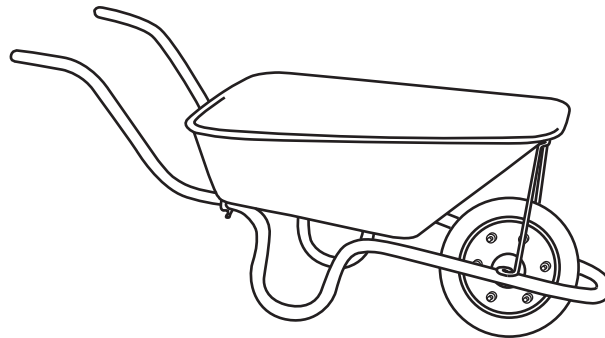

Fig. 2

(a) (i) Add a label to Fig. 2 to indicate the position of the fulcrum. [1]

(ii) State what is meant by the term 'fulcrum'.
..... [1]

(iii) State the effect on the effort required if the wheelbarrow handles were made longer.
..... [1]

(iv) Explain how the position of the load from the fulcrum influences the effort required.
.....
.....
.....
.....
..... [3]

(b) Fig. 3 shows a motor used to power a rope winch. The system uses a V-belt as shown.

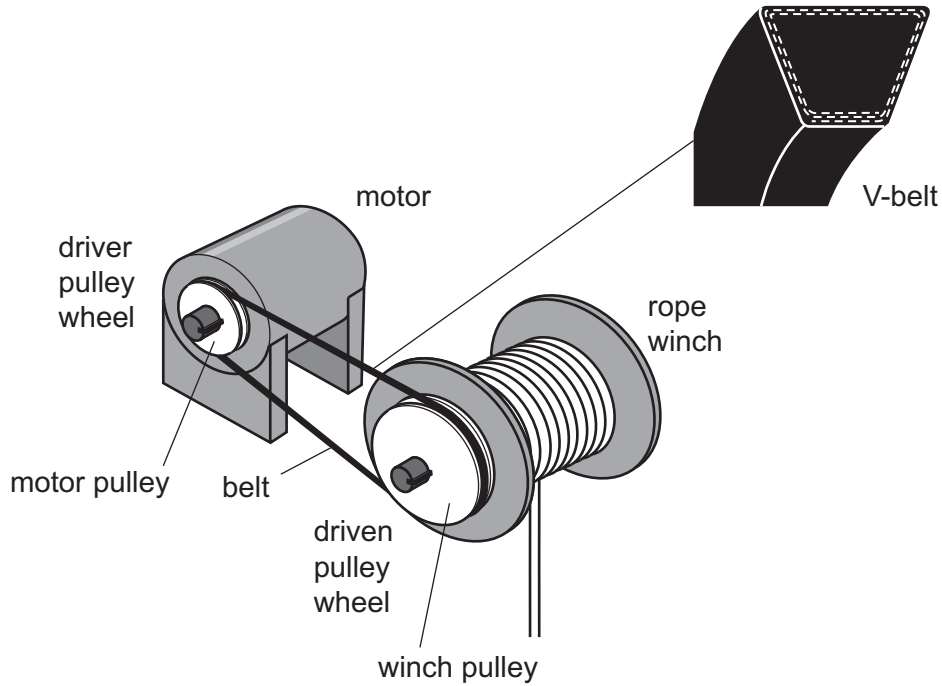

Fig. 3

(i) Give **one** disadvantage of using the V-belt shown in Fig. 3 compared to using a toothed belt.

..... [1]

(ii) Give **one** alternative way of connecting the motor to the rope winch.

..... [1]

(iii) The motor pulley has a diameter of 80mm and the winch pulley has a diameter of 160mm. Calculate the velocity ratio.

.....
 [1]

(iv) The motor pulley rotates at 60rpm. Calculate the speed of the driven pulley wheel.

.....
 [1]

3 (a) Fig. 4 shows a motor used in a hairdryer.

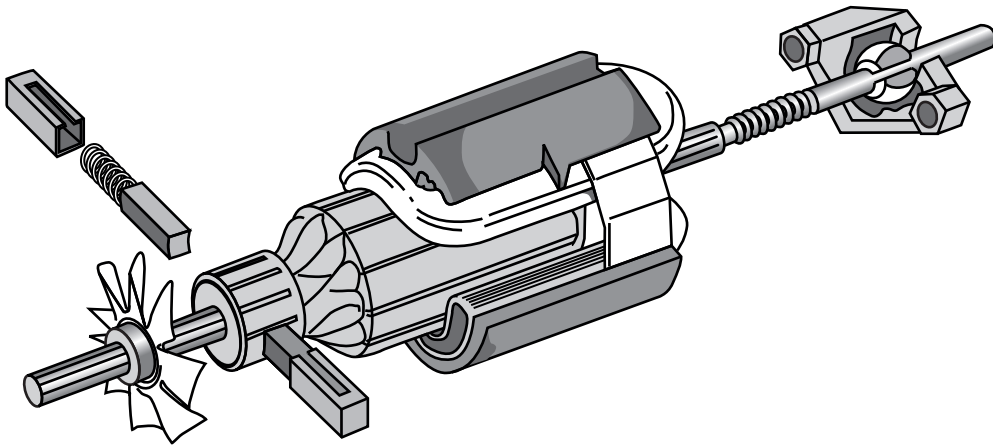

Fig. 4

(i) Add labels to Fig. 4 to show any **two** component parts of the motor. [2]

(ii) State the function of **one** of the parts that you have labelled in Fig. 4.

 [1]

(iii) Calculate the current usage of a 230V hairdryer used at a constant power setting of 500W. Give the units in your answer.

 [2]

(iv) Complete the statement below.
 The hairdryer motor converts energy to
 energy, to turn a fan. An electrical current is passed
 through the heater element coils. The coils have
 which creates energy. [4]

(b) Give **one** different example of energy conversion in engineering.
 energy to energy. [1]

6
BLANK PAGE

PLEASE DO NOT WRITE ON THIS PAGE

4 (a) Give **one** example of a hydro-mechanical application. [1]

.....

(b) Describe how a hydro-mechanical application can be used to control the flow of water. [3]

.....

.....

.....

.....

.....

.....

(c) Fig. 5 shows an engine piston and crankshaft assembly.

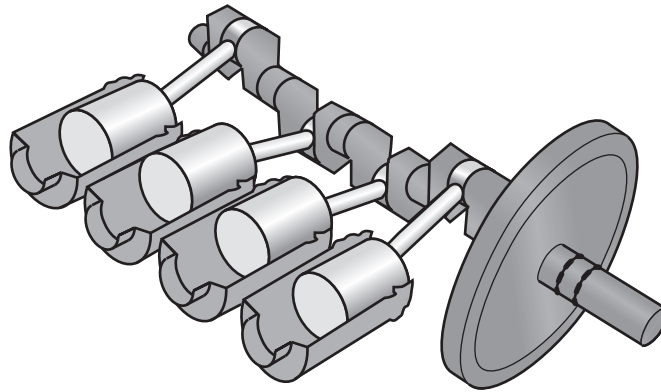

Fig. 5

(i) State the type of rotating force produced by the engine. [1]

.....

(ii) Describe a method that can be used to connect the engine to an external component that uses the output of the engine. [3]

.....

.....

.....

.....

.....

(iii) Give **two** ways that a hydraulic pump could be connected to an engine assembly to provide power to lifting equipment. [2]

1

2

5 Fig. 6 shows a manually operated pneumatic circuit.

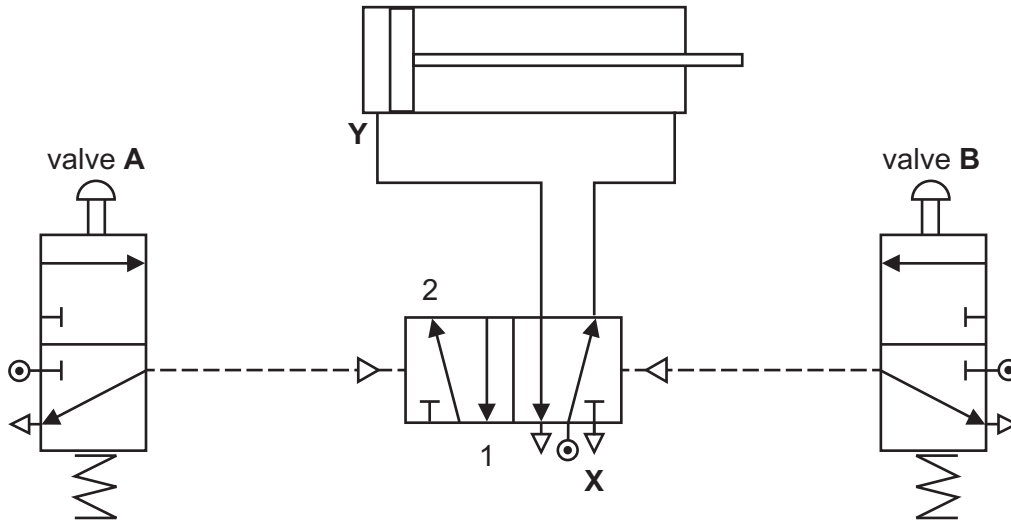

Fig. 6

- (a) (i) The statements below describe the stages of the outstroke operation of the double acting cylinder circuit in Fig. 6.

Draw lines to show the correct sequence of these stages.

One has been completed for you.

Sequence	Stage
1	Air is exhausted through port X
2	Port 2 is connected to port Y on the double acting cylinder
3	The double acting cylinder outstrokes
4	Operator presses the button on valve A
5	Valve A changes state to supply air to the 5/2 valve
6	The 5/2 valve changes state

[4]

(ii) State the purpose of valve **B** in Fig. 6.

..... [1]

(iii) State **one** change to the circuit that would be needed to replace the double acting cylinder with a single acting cylinder.

..... [1]

(iv) Add a label to Fig. 6 to show **one** pilot air control line. [1]

(b) Explain how pressure is created in a pneumatic system.

.....
.....
.....
.....
..... [3]

ADDITIONAL ANSWER SPACE

If additional space is required, you should use the following lined page(s). The question number(s) must be clearly shown in the margin(s).

A large area of lined paper for writing, consisting of 25 horizontal dotted lines. A solid vertical line runs down the left side of the page, creating a margin. The rest of the page is open for writing.

Blank writing area with horizontal dotted lines and a vertical solid line on the left side.



Copyright Information

OCR is committed to seeking permission to reproduce all third-party content that it uses in its assessment materials. OCR has attempted to identify and contact all copyright holders whose work is used in this paper. To avoid the issue of disclosure of answer-related information to candidates, all copyright acknowledgements are reproduced in the OCR Copyright Acknowledgements Booklet. This is produced for each series of examinations and is freely available to download from our public website (www.ocr.org.uk) after the live examination series. If OCR has unwittingly failed to correctly acknowledge or clear any third-party content in this assessment material, OCR will be happy to correct its mistake at the earliest possible opportunity.

For queries or further information please contact The OCR Copyright Team, The Triangle Building, Shaftesbury Road, Cambridge CB2 8EA.

OCR is part of the Cambridge Assessment Group; Cambridge Assessment is the brand name of University of Cambridge Local Examinations Syndicate (UCLES), which is itself a department of the University of Cambridge.