

Thursday 16 June 2022 – Morning

A Level Physics A

H556/03 Unified physics

Time allowed: 1 hour 30 minutes



You must have:

- the Data, Formulae and Relationships Booklet

You can use:

- a scientific or graphical calculator
- a ruler (cm/mm)



Please write clearly in black ink. **Do not write in the barcodes.**

Centre number

| | | | | |
|--|--|--|--|--|
| | | | | |
|--|--|--|--|--|

Candidate number

| | | | |
|--|--|--|--|
| | | | |
|--|--|--|--|

First name(s)

Last name

INSTRUCTIONS

- Use black ink. You can use an HB pencil, but only for graphs and diagrams.
- Write your answer to each question in the space provided. If you need extra space use the lined pages at the end of this booklet. The question numbers must be clearly shown.
- Answer **all** the questions.
- Where appropriate, your answers should be supported with working. Marks might be given for a correct method, even if your answer is wrong.

INFORMATION

- The total mark for this paper is **70**.
- The marks for each question are shown in brackets [].
- Quality of extended response will be assessed in questions marked with an asterisk (*).
- This document has **20** pages.

ADVICE

- Read each question carefully before you start your answer.

2

Answer **all** the questions.

1 The table shows some data on the planet Venus.

| | |
|---|-----------------------|
| Mass/kg | 4.87×10^{24} |
| Radius/km | 6050 |
| Density of atmosphere at surface/kg m⁻³ | 65 |
| Period of rotation about its axis/hours | 5830 |

(a) Calculate the magnitude of the gravitational field strength g at the surface of Venus.

Give your answer to **3** significant figures.

$$g = \dots\dots\dots \text{N kg}^{-1} \text{ [3]}$$

(b) Two identical space probes, **A** and **B**, land on a flat surface on Venus.

Probe **A** lands at the north pole. Probe **B** lands on the equator.

Each probe has mass 760 kg and volume 1.7 m^3 .

(i) Calculate the centripetal acceleration a of probe **B** at the equator due to the rotation of Venus about its axis.

$$a = \dots\dots\dots \text{ms}^{-2} \text{ [3]}$$

(ii) The atmosphere exerts the same upthrust on each probe.

Using your answer to (a), calculate the upthrust acting on each probe.

upthrust = N [3]

(iii) Explain which probe will experience the greater normal contact force from the surface of Venus.

.....

.....

.....

.....

.....

.....

..... [3]

PLEASE DO NOT WRITE ON THIS PAGE

- 2 A student investigates the oscillations of a uniform rod of length L which is pivoted at the top, as shown in **Fig. 2.1**.

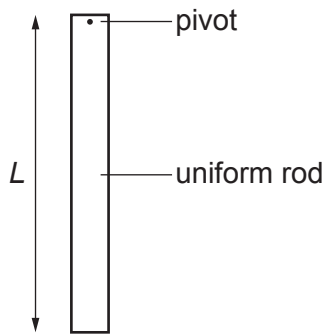

Fig. 2.1

- (a) Describe how to determine accurately the period T of oscillations of this rod.

.....

.....

.....

..... [2]

(b) The relationship between the frequency f of the oscillations of the rod and its length L is

$$f = \frac{1}{2\pi} \sqrt{\frac{3g}{2L}},$$

where g is the acceleration of free fall.

The student varies the length L of the rod and determines the period T for each length.

The student plots a graph of T^2 against L , shown in **Fig. 2.2**. A line of best fit has already been drawn.

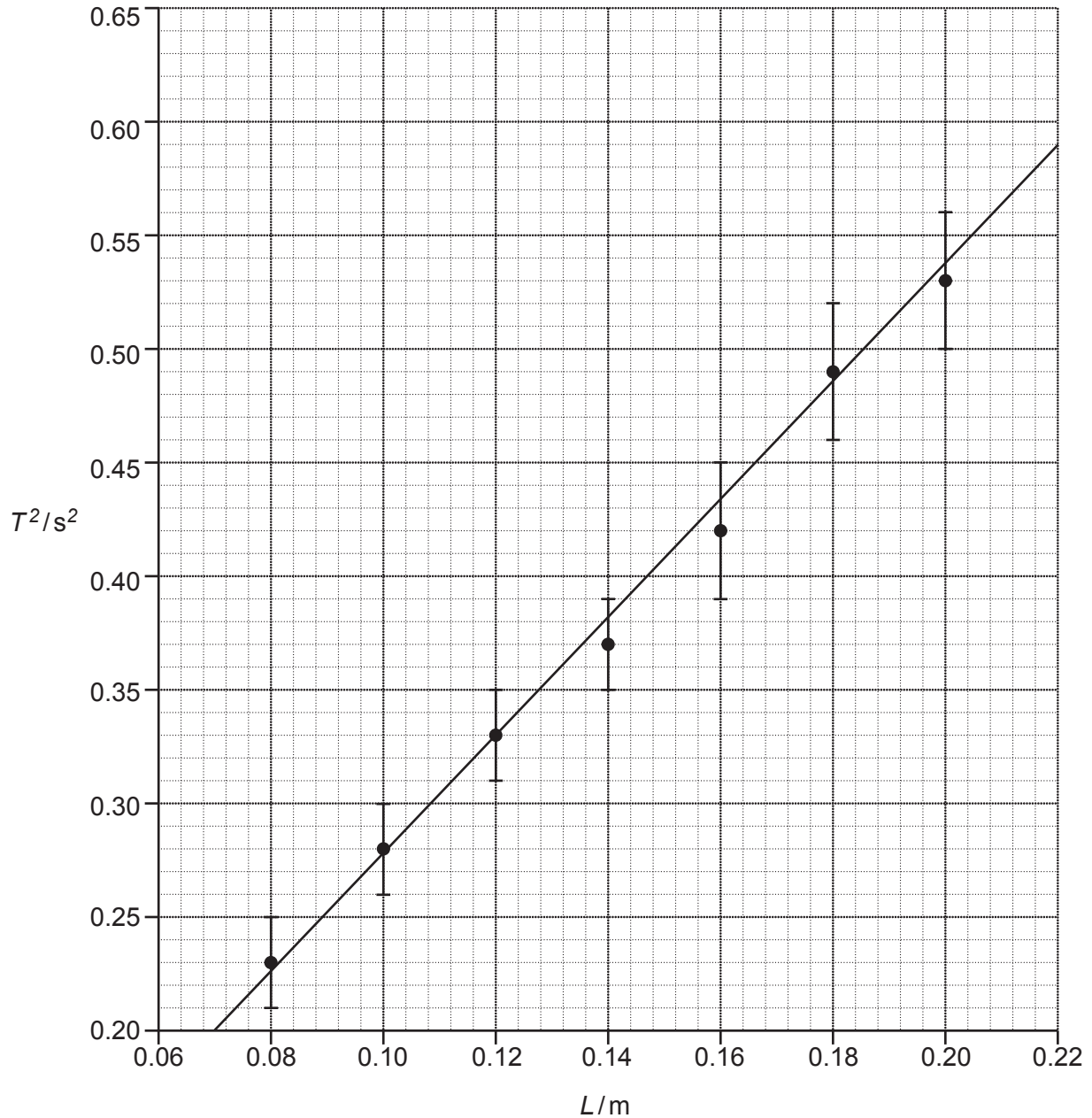

Fig. 2.2

- (i) Show that the gradient of the graph is given by the equation

$$\text{gradient} = \frac{8\pi^2}{3g}$$

[2]

- (ii) The gradient of the line of best fit on **Fig. 2.2** is $2.64 \text{ s}^2 \text{ m}^{-1}$.

Use this value to determine g .

$$g = \dots\dots\dots \text{ m s}^{-2} \text{ [2]}$$

- (iii) Draw a line of worst fit on **Fig. 2.2**. [1]

- (iv) Use your line of worst fit to calculate the percentage uncertainty in g .

$$\text{percentage uncertainty} = \dots\dots\dots \% \text{ [3]}$$

- (v) Use the true value of g (9.81 m s^{-2}) to evaluate the accuracy of the student's value of g from this experiment. Include a calculation in your answer.

.....

.....

.....

.....

..... [2]

- 3 (a) In beta-plus decay, a proton decays into three other particles.

Write a nuclear equation for this process.

[2]

- (b)* A student, supervised by their teacher, carries out an experiment with three unlabelled radioactive sources.

The student is told that each source emits only one type of radiation. One emits gamma rays, one emits beta-minus particles and one emits beta-plus particles.

The student has the following equipment:

- a selection of materials with different thicknesses
- a strong magnet
- a radiation counter (GM tube and counter).

Explain how the student can use this equipment to determine safely which radiation each source emits.

You may use the space below to draw a diagram.

[6]

.....

.....

.....

.....

.....

.....

.....

.....

.....

.....

.....

.....

.....

.....

.....

.....

.....

.....

.....

.....

.....

.....

Additional answer space if required

.....

.....

.....

.....

.....

.....

.....

.....

.....

.....

.....

4 Astronomers can detect microwave background radiation coming from space in every direction. The temperature of this microwave radiation is 2.7 K and its **total** intensity is about $3 \times 10^{-6} \text{ W m}^{-2}$.

(a) Describe the origin of the microwave background radiation.

.....

 [2]

(b) The figure below shows how the intensity of the microwave background radiation varies with its wavelength λ .

The **peak** intensity is at a wavelength of 1.1 mm.

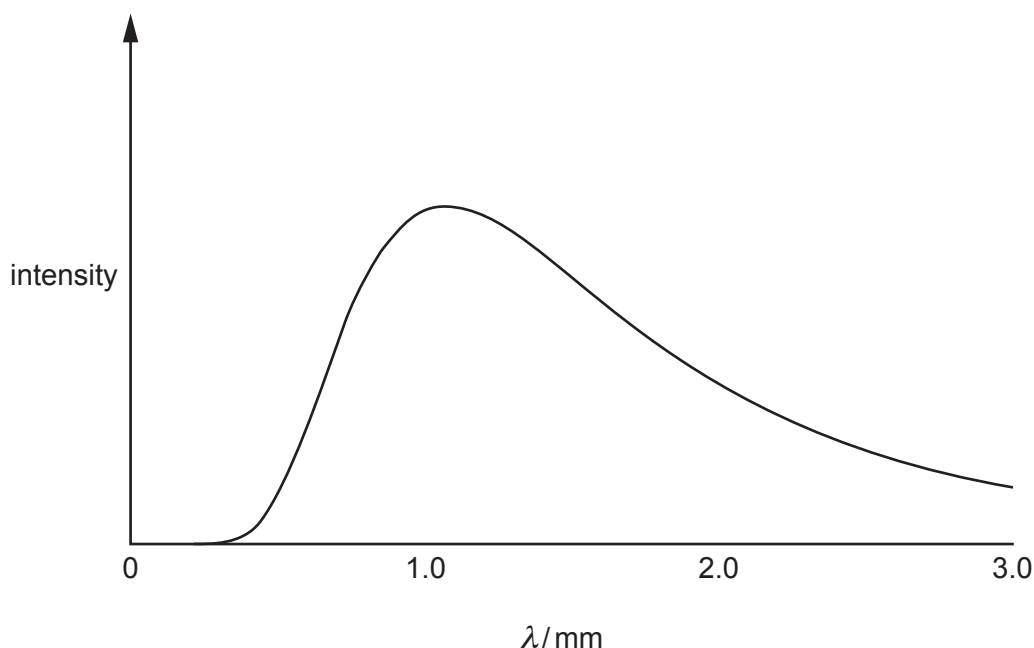

This spectrum of microwave background radiation changes with temperature according to Wien's displacement law.

(i) Suggest and explain how the spectrum might have looked in the distant past. You may draw on the figure to support your answer.

.....

 [2]

- (ii) Calculate the energy of a photon which has a wavelength of 1.1 mm.

energy = J [2]

- (iii) Estimate the number of photons of microwave background radiation incident per second on the back of your hand.

Assume that all emitted photons have the energy calculated in (ii), and that the back of your hand has a surface area of 150 cm^2 .

number of photons per second = s^{-1} [2]

- (iv) A scientist suggests that the microwave background radiation could be used as an energy source.

The scientist proposes using large tanks of water to absorb the microwave radiation.

Estimate the maximum rise in temperature that could be produced per second for a large cylindrical tank of depth 5.0 m. Assume that all microwave radiation incident on the top of the tank is absorbed.

density of water = 1000 kg m^{-3}

specific heat capacity of water = $4200 \text{ J kg}^{-1} \text{ K}^{-1}$

maximum rise in temperature per second = $^{\circ}\text{C s}^{-1}$ [3]

12
BLANK PAGE

PLEASE DO NOT WRITE ON THIS PAGE

- 5 A student experiments with microwaves emitted from a transmitter. The frequency f of the microwaves from the transmitter can be adjusted.

(a) The microwaves are produced by an alternating current in the transmitter.

In one experiment, f is 11 GHz. In a wire in the transmitter, the magnitude of the **maximum** alternating current is 20 mA. The wire has cross-sectional area $1.4 \times 10^{-8} \text{ m}^2$ and is made of a metal with free electron number density $8.0 \times 10^{28} \text{ m}^{-3}$.

- (i) Show that the maximum drift velocity of each free electron in the wire is about 0.1 mm s^{-1} .

[3]

- (ii) The student models the average motion of the free electrons in the wire as simple harmonic motion.

Use your answer to (i) to calculate the amplitude A of this motion.

$A = \dots\dots\dots \text{ m}$ [3]

- (iii) Without further calculation, explain how the maximum acceleration of a free electron varies as the frequency f is adjusted, provided that the maximum alternating current remains constant.

.....

 [2]

(b) The student connects two microwave transmitters **X** and **Y**, and places them in front of a microwave detector **D**, as shown in the diagram below.

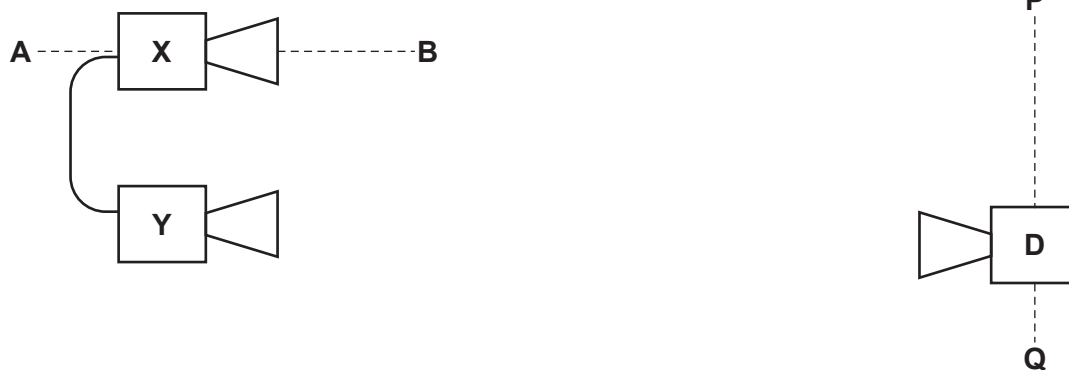

The transmitters **X** and **Y** produce **coherent** vertically polarised microwaves with the same frequency f .

The detector **D** is sensitive to vertically polarised microwaves only.

When the detector **D** is moved along the line **PQ**, a pattern of maximum and minimum intensity is observed. Adjacent maxima are separated by a distance x .

(i)* Explain:

- why this pattern of intensity occurs
- the expected relationship between the frequency f and the distance x
- how to verify this relationship experimentally.

[6]

.....

.....

.....

.....

.....

.....

.....

.....

.....

.....

.....

.....

.....

.....

.....

.....

.....

.....

.....

.....

.....

.....

.....

.....
.....

Additional answer space if required

.....
.....
.....
.....
.....
.....
.....
.....
.....

- (ii) Transmitter **X** is rotated about the line **AB** and the experiment is repeated at different orientations until it has been rotated by 180° .

Describe and explain the observed patterns of maximum and minimum intensity.

.....
.....
.....
.....
.....
.....
.....
.....
..... [3]

16
BLANK PAGE

PLEASE DO NOT WRITE ON THIS PAGE

- 6 (a) Define the **time constant** of a circuit containing a capacitor of capacitance C and a resistor of resistance R .

.....
 [1]

- (b) The capacitor circuit shown in **Fig. 6.1** can be used to smooth oscillating electrical signals.

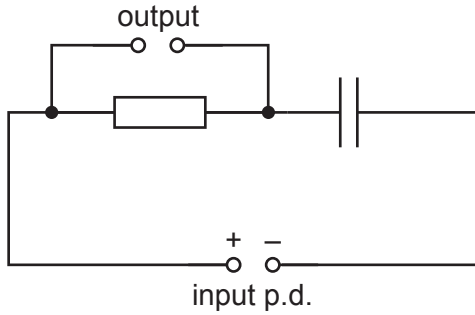

Fig. 6.1

- (i) **Fig. 6.2** shows the input signal of potential difference (p.d.) V against time t .

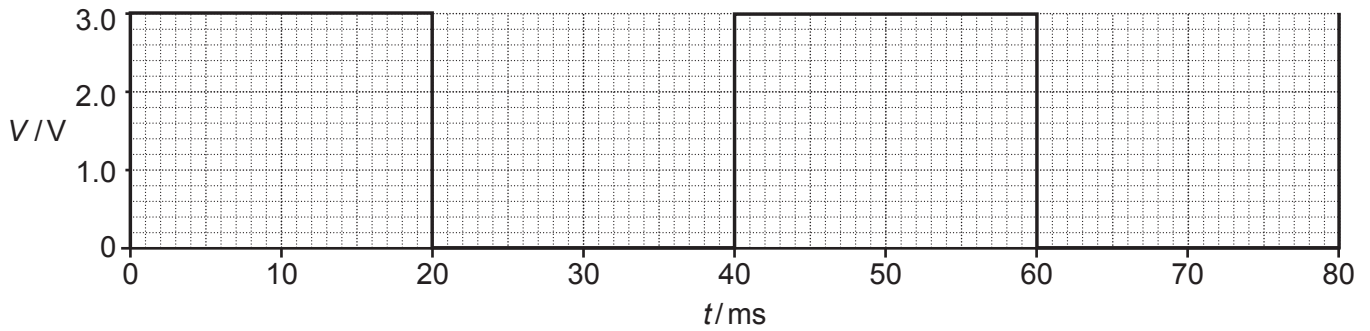

Fig. 6.2

Calculate the frequency f of this input signal.

$f = \dots\dots\dots$ Hz [2]

(ii) **Fig. 6.3** shows the variation of the charge Q on the positive plate of the capacitor with time t .

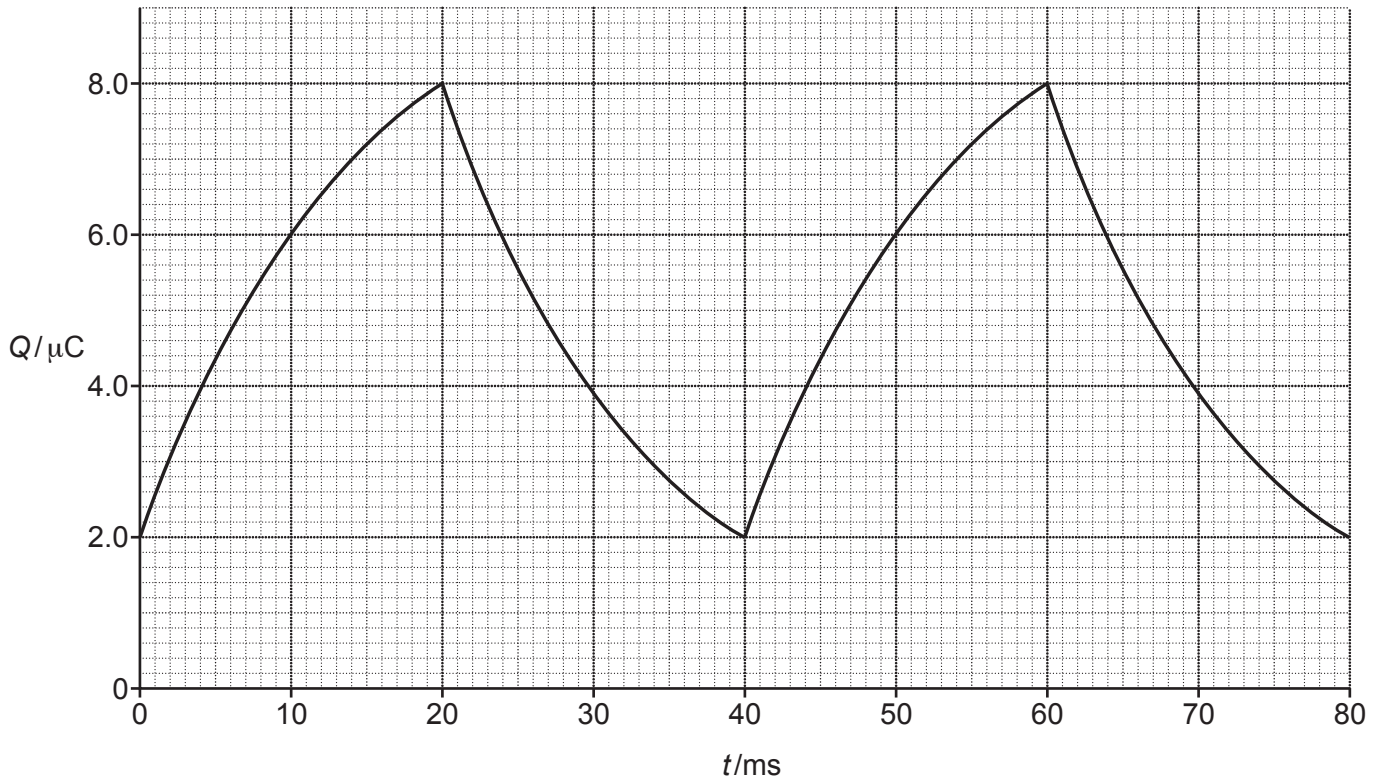

Fig. 6.3

Use a discharging section of the graph in **Fig. 6.3** to determine the time constant of the circuit. Give your answer in ms.

time constant = ms [2]

(iii) By drawing a suitable tangent to the graph in **Fig. 6.3**, calculate the maximum current in the resistor.

maximum current = A [2]

- (iv) On Fig. 6.4 below, sketch the variation of the current I in the resistor with time t . Include an appropriate label and scale on the vertical axis.

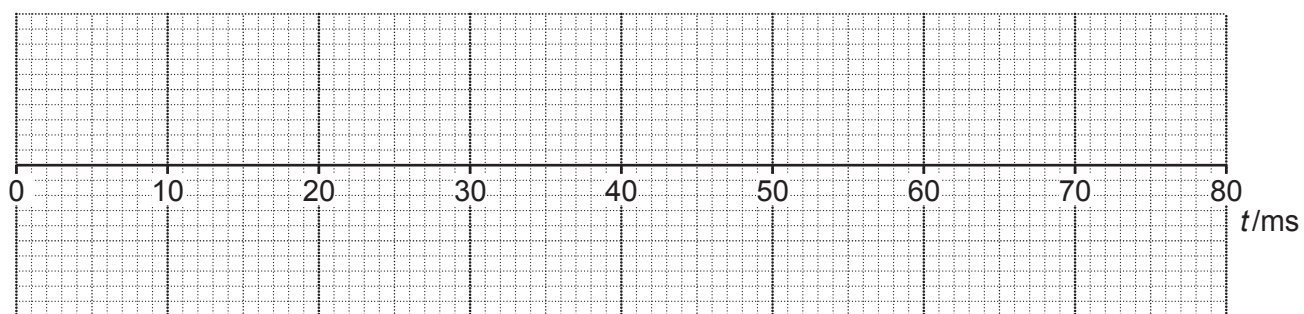

Fig. 6.4

[3]

END OF QUESTION PAPER

ADDITIONAL ANSWER SPACE

If additional space is required, you should use the following lined page(s). The question number(s) must be clearly shown in the margin(s).

A large rectangular area with a solid vertical line on the left side and horizontal dotted lines across the rest of the page, providing space for writing answers.



Copyright Information

OCR is committed to seeking permission to reproduce all third-party content that it uses in its assessment materials. OCR has attempted to identify and contact all copyright holders whose work is used in this paper. To avoid the issue of disclosure of answer-related information to candidates, all copyright acknowledgements are reproduced in the OCR Copyright Acknowledgements Booklet. This is produced for each series of examinations and is freely available to download from our public website (www.ocr.org.uk) after the live examination series.

If OCR has unwittingly failed to correctly acknowledge or clear any third-party content in this assessment material, OCR will be happy to correct its mistake at the earliest possible opportunity.

For queries or further information please contact The OCR Copyright Team, The Triangle Building, Shaftesbury Road, Cambridge CB2 8EA.

OCR is part of Cambridge University Press & Assessment, which is itself a department of the University of Cambridge.