

**A LEVEL**

Examiners' report

**PHYSICS B**  
**(ADVANCING PHYSICS)**

---

**H557**

For first teaching in 2015

**H557/03 Summer 2023 series**

# Contents

Introduction .....	3
Paper 3 series overview .....	4
Section A .....	5
Question 1 (a) (i), (ii), & (iii) .....	5
Question 1 (a) (iv) .....	7
Question 1 (b)* .....	8
Question 2 (a) (i) .....	10
Question 2 (a) (ii) .....	10
Question 2 (b) .....	11
Question 2 (c) (i) .....	12
Question 2 (c) (ii) .....	12
Question 3 (a) .....	13
Question 3 (b) .....	14
Question 3 (c) (i) .....	15
Question 3 (c) (ii) .....	15
Section B .....	16
Question 4 (a) (i) .....	16
Question 4 (a) (ii) .....	17
Question 4 (a) (iii) .....	18
Question 4 (a) (iv) .....	19
Question 4 (b) (i) .....	20
Question 4 (b) (ii) .....	21
Question 4 b (iii)* .....	22

## Introduction

Our examiners' reports are produced to offer constructive feedback on candidates' performance in the examinations. They provide useful guidance for future candidates.

The reports will include a general commentary on candidates' performance, identify technical aspects examined in the questions and highlight good performance and where performance could be improved. A selection of candidate answers is also provided. The reports will also explain aspects which caused difficulty and why the difficulties arose, whether through a lack of knowledge, poor examination technique, or any other identifiable and explainable reason.

Where overall performance on a question/question part was considered good, with no particular areas to highlight, these questions have not been included in the report.

A full copy of the question paper and the mark scheme can be downloaded from OCR.

### Would you prefer a Word version?

Did you know that you can save this PDF as a Word file using Acrobat Professional?

Simply click on **File > Export to** and select **Microsoft Word**

(If you have opened this PDF in your browser you will need to save it first. Simply right click anywhere on the page and select **Save as . . .** to save the PDF. Then open the PDF in Acrobat Professional.)

If you do not have access to Acrobat Professional there are a number of **free** applications available that will also convert PDF to Word (search for PDF to Word converter).

## Paper 3 series overview

This paper is worth 60 marks out of the total 270 marks for the qualification. It includes content from all teaching modules but places emphasis on practical skills. This includes significant work on analysis of measuring results, calculating uncertainties and graphical work. On the most part the paper consists of structured questions covering problem solving and calculations, as well as Level of Response (LOR) questions. This paper appeared to be accessible to most candidates as there was a good spread of marks and there was little evidence that candidates had run out of time.

Candidates who did well on this paper generally:	Candidates who did less well on this paper generally:
<ul style="list-style-type: none"><li>• had a good understanding of the practical experiments on this paper</li><li>• laid out calculations clearly</li><li>• wrote explanations and descriptions concisely and used appropriate scientific terminology.</li></ul>	<ul style="list-style-type: none"><li>• seemed less familiar with the experiments on this paper</li><li>• misread scales on the graphs and made power of ten errors in calculations</li><li>• were unable to draw the correct circuit diagram for charging/discharging a capacitor in Question 3 (a)</li><li>• struggled to explain electromagnetic induction correctly in Question 4.</li></ul>

## Section A

### Question 1 (a) (i), (ii) and (iii)

- 1 A cell can be made by inserting a zinc cathode and a copper anode into a lemon. A high resistance voltmeter is used in the circuit shown in **Fig. 1.1** to measure the p.d. across the lemon when different resistors are placed across the cell.

**Fig. 1.1**

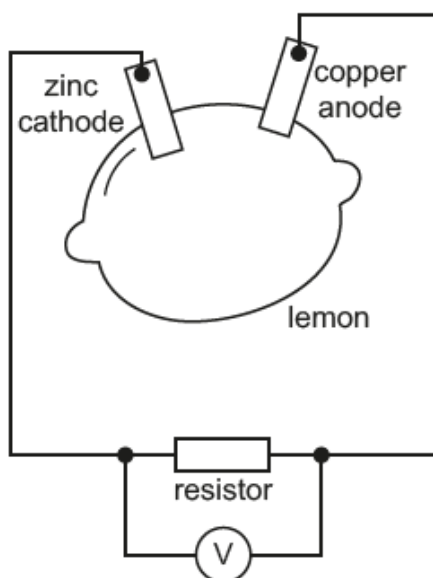

- (a) **Table 1** below shows the data recorded.

**Table 1**

resistance /k $\Omega$	potential difference /mV	current / $\mu$ A
3.3	540	164
6.6	666	101
10.0	738	
13.3	765	
16.6	784	47
20.0	812	41

- (i) Calculate the current and complete the missing rows in **Table 1**.

[1]

(ii) Plot the missing points on the graph in Fig. 1.2 and draw the line of best fit. [2]

Fig. 1.2

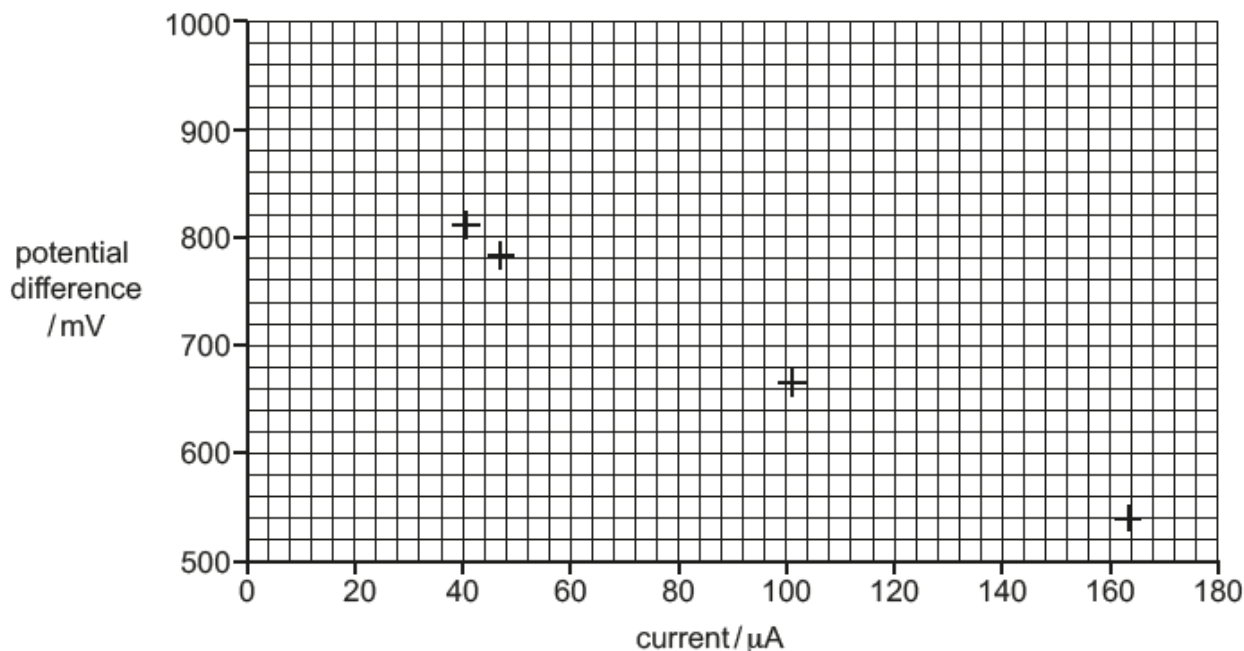

(iii) Find the gradient of the line of best fit and hence calculate the lemon's internal resistance, in ohms,  $\Omega$ . Show your working.

Internal resistance = .....  $\Omega$  [3]

Nearly all candidates correctly calculated the two values of current in part (i) and plotted them onto the graph in part (ii). There were a handful of candidates who misread the scales and put one or other of the plots in the incorrect place. Most candidates were able to draw an acceptable straight line through the plotted points on the graph.

In part (iii) most candidates showed that they knew how to calculate the gradient of the line, but many gave a positive value for a negative gradient. Most of the candidates did realise that the value of gradient was equal to the negative value of internal resistance but were unable to show how or why this was the case.

### Question 1 (a) (iv)

(iv) A student suggests that two lemon cells in series could be used to run a 1.5V, 0.45W filament lamp. Explain why this is not correct.

.....

.....

.....

..... [2]

Candidates were told here that the two lemons in series would be unable to run the filament lamp so they needed to explain why this was not the case. Many candidates correctly calculated the current required by the filament lamp but then did not clearly explain or calculate that the current provided by the lemons would be very much lower than this value. Very few candidates used a potential divider argument to explain this situation.

### Question 1 (b)\*

(b)\* The experiment is repeated with two lemon cells in series and with two lemon cells in parallel.

For two lemons in series, the emf expression is found to be

$$2\varepsilon = V + 2I_{\text{series}}r$$

where  $\varepsilon$  is the emf of one lemon cell and  $r$  is the internal resistance of a single lemon cell.

Describe the effects of these combinations on the relationship between current and potential difference. In your answer, you should:

- derive the emf expression for two lemon cells connected in parallel in terms of  $\varepsilon$  and  $r$ .
- compare the gradients and intercepts of all three experiments and sketch the V-I graphs to compare the two lemon V-I relationships to the graph for one lemon in Fig. 1.2.

.....  
.....  
.....  
.....  
.....  
..... [6]

Many candidates were able to draw a graph for the two lemons in series and to describe how this differed from the graph for a single lemon. Describing the situation for the two lemons in parallel was much more challenging. Many candidates suggested incorrectly that the total emf was either twice that of a single lemon or a quarter. Many that did draw a less steep gradient were unable to explain the reason clearly.



## Exemplar 1

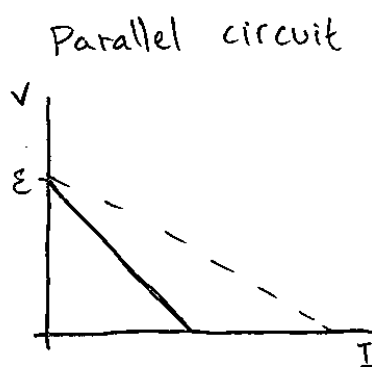
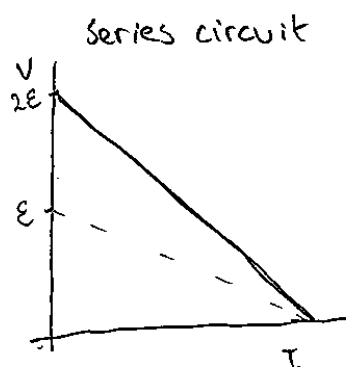

dotted line is the relationship in single cell circuit.

$$\underline{\underline{E = V + \frac{1}{2} I_{\text{parallel}} r}}$$

For two cells in series, a much higher potential difference would be seen for the same current drawn. Therefore the  $V$ - $I$  gradient would be much more negative, double that of the single cell circuit. The  $y$ -intercept would be ~~as~~ twice that for the single cell as the intercept represents  $E$ .

For two cells in parallel, there would be a smaller potential difference, despite the emf remaining constant. This is because the two cell connected across the same terminals will attempt to push against each other and equalize at a half of their combined total. The potential difference would be ~~less~~ <sup>less than</sup> its value in a single cell circuit as the second cell increases the internal resistance. [6]

Here, the description for the series circuit is correct and communicated well. The corresponding sketch graph is correct and annotated clearly. The graph for the parallel circuit has the correct intercept, but gradient is incorrectly drawn as being steeper than that for a single lemon. The equation for the two lemons in parallel is correct but the candidate has misinterpreted the gradient, so this is not good enough for a Level 3 response.

### Question 2 (a) (i)

2 This question is about an experiment to determine the value of the Planck constant  $h$ .

A student increases the potential difference across a blue LED until it just starts to glow. The student measures the value of this pd using a multimeter. This is known as the 'striking voltage'. The measurement is repeated, and a dot-plot is drawn, as shown in Fig. 2.1.

Fig. 2.1

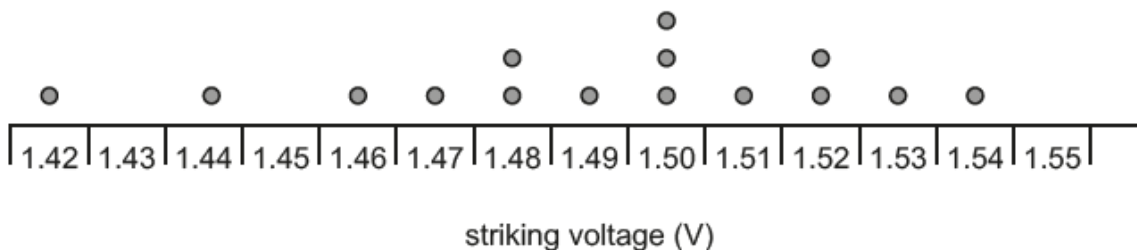

(a) (i) Calculate the mean value of striking voltage and its absolute uncertainty.

Mean striking voltage = .....  $\pm$  ..... V [2]

Almost all the candidates were able to calculate a mean value but some candidates incorrectly decided that 1.42 was an outlier. Outliers are only usually discounted if they are twice the spread from the mean value which 1.42 is not. There were many correct methods to find the uncertainty but common errors included multiplying the precision (0.01 V) by 15.

### Question 2 (a) (ii)

(ii) Describe **one** significant cause of uncertainty in this measurement and suggest a method which would reduce the uncertainty.

.....

.....

..... [2]

Many candidates had the correct idea here that determining exactly when the LED begins to glow is very subjective and could lead to inconsistencies. Most candidates seemed familiar with this experiment as they suggested to view the LED down a tube or to turn the lights off. Several candidates were concerned about the precision of the multimeter.

Question 2 (b)

(b) The student then repeats the measurement of striking voltage for LEDs of different colours. She refers to the manufacturer's data to find the value of wavelength for each LED and plots a graph of  $1/\text{wavelength}$  (on the x-axis) against striking voltage (on the y-axis). The graph is shown in Fig. 2.2.

The gradient of this line of best fit =  $8.90 \times 10^{-7} \text{ V m}$ .

Fig. 2.2

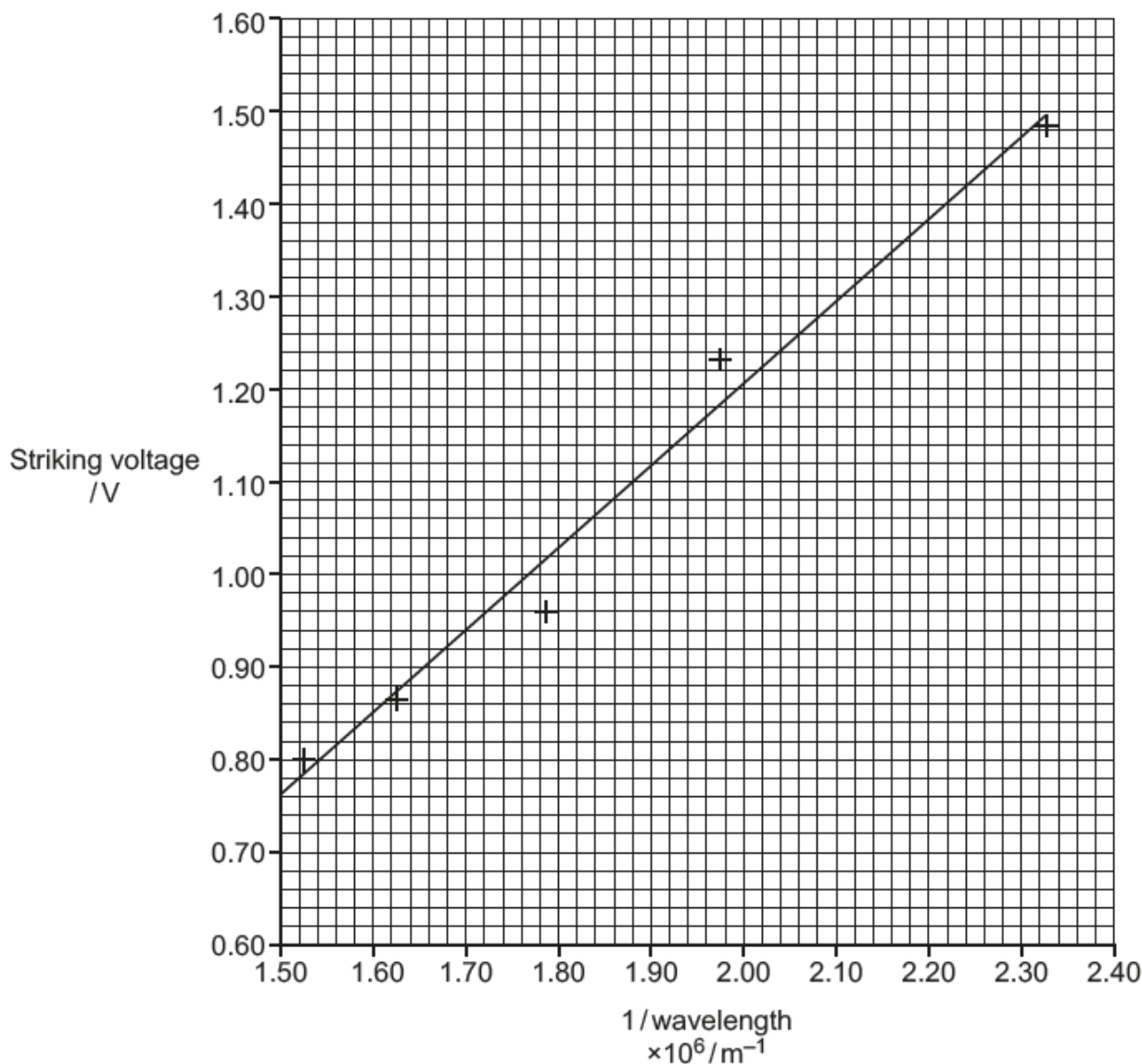

- (i) Using the value for uncertainty found in (a)(i), add vertical error bars to all the plotted points and draw a steepest acceptable line through the error bars. [2]
- (ii) Hence calculate the absolute uncertainty of the gradient value.

Absolute uncertainty of gradient =  $\pm$  ..... Vm [2]

Most candidates were able to correctly draw the error bars onto the graph and most of them drew an acceptable steepest line, although a few did not use the full extent of the error bars. Most were able to use a correct method for finding the gradient of their line, with a few misreading the scale, and subsequently the uncertainty in the gradient value. Some candidates unnecessarily drew both a steepest and a shallowest line and then found half the difference in the two gradients as the uncertainty. Some candidates calculated their own gradient of the printed line despite being told its value in the question.

### Question 2 (c) (i)

(c) (i) Show that the Planck constant,  $h = \text{gradient} \times \frac{e}{c}$ .

[2]

Some candidates answered this question well, but others confused themselves by taking  $e$  as energy and/or  $V$  as speed. Some tried substituting values, missing the point of the question and a few attempted dimensional analysis here.

### Question 2 (c) (ii)

- (ii) The gradient of the line of best fit is  $8.90 \times 10^{-7} \text{ V m}$ .  
Use this value to calculate a value of the Planck constant.  
Include a value for absolute uncertainty in your answer.

Planck constant = .....  $\pm$  ..... Js [3]

This calculation was on the whole done well, and candidates showed a variety of correct methods to find the uncertainty. Common errors were to just give the uncertainty found in part (b) (ii) or to omit the correct power of ten in the uncertainty.

### Question 3 (a)

3 This question is about the discharge of a capacitor.

(a) You are provided with the following apparatus:

- variable power supply (0 – 12 V)
- capacitor of unknown capacitance
- resistor of value 4.7 kΩ
- multimeter
- leads and switches
- stopwatch

Describe a method to record the potential difference,  $V$ , across the capacitor as it discharges, using the apparatus listed. Include a circuit diagram in your answer.

.....

.....

.....

.....

.....

.....

..... [4]

Many candidates did not draw a valid circuit diagram for this experiment; many putting the cell, resistor, and capacitor all in series with no mechanism for swapping from a charging circuit to a discharging circuit. Some candidates did not use the correct circuit symbols, but most were able to describe a basic method for the experiment. A few candidates explained how to process the results, which was not asked for in this question.

Question 3 (b) (i), (ii) and (iii)

(b) Values of  $V$  as the capacitor discharges through the  $4.7\text{ k}\Omega$  resistor are recorded at 10 s intervals in **Table 3**.

**Table 3**

time $t/\text{s}$	potential difference across capacitor $V/\text{V}$	$\ln V$	
0	7.00	1.946	
10	4.54	1.513	
20	2.97		
30	1.98		
40	1.35	0.300	
50	0.94	-0.062	

(i) Capacitor discharge is an example of exponential decay and follows the equation

$$V = V_0 e^{-\frac{t}{RC}}$$

Complete the  $\ln V$  column in **Table 3** and then perform a mathematical test on the data to show that it follows exponential decay.

You may use the extra column in the table for your working. [3]

(ii) Show that the value of the time constant,  $\tau$  is approximately 25 s.

[1]

(iii) Calculate the value of the capacitance.

Capacitance = ..... F [1]

Almost all the candidates were able to calculate the missing values of  $\ln V$  in the table, and most did go on to calculate the difference in successive log values or ratio of successive  $V$  values correctly, but then omitted to comment on the values in part (i). Common errors here were to find a ratio of  $\ln V$  values, or to find the proportion of the initial  $V$ , which then would have needed further manipulation in order to test that it was exponential decay. A few candidates tried to work out how long  $V$  took to halve, but this was difficult with discrete values in a table. Some candidates actually calculated either the time constant or the capacitance at this part of the question, but they were the answers to parts (ii) and (iii). In part (ii) most candidates just substituted the largest and smallest values of  $V$  into the equation  $V = V_0 e^{-\frac{t}{RC}}$ , and used  $t = 50\text{ s}$ , rather than the average ratio value calculated in part (i). Nearly all candidates were able to calculate capacitance in part (iii).

### Question 3 (c) (i)

(c) There is a general rule of thumb used by electronic engineers that the time taken for a capacitor to discharge completely is  $5\tau$ .

(i) Starting from the equation given in (b)(i) and repeated below show that when  $t = 5\tau$ , the energy stored in the capacitor,  $E = 4.5 \times 10^{-5} E_0$ , where  $E_0$  is the energy stored in the fully charged capacitor.

$$V = V_0 e^{\frac{-t}{RC}}$$

[3]

Many candidates did successfully show that the ratio of energy was  $4.5 \times 10^{-5}$ , more often than not, by calculating values of initial energy and energy after  $5\tau$ , rather than the algebraic method.

#### Assessment for learning



When candidates are asked to 'show that...', they are expected to write out equations clearly before substituting numbers in to calculate a value and should write every step of the calculation down clearly in a logical order.

### Question 3 (c) (ii)

(ii) Justify why this rule of thumb is useful to engineers.

.....  
 ..... [1]

Many candidates just suggested that this would make calculations simpler, somewhat missing the practicality of engineers needing to know when the energy or charge remaining in a capacitor become negligible and therefore safe to handle.

## Section B

### Question 4 (a) (i)

4 This question is about inducing an emf in a coil of wire.

Fig. 4.1 shows a coil of wire perpendicular to a uniform magnetic field.

Fig. 4.1

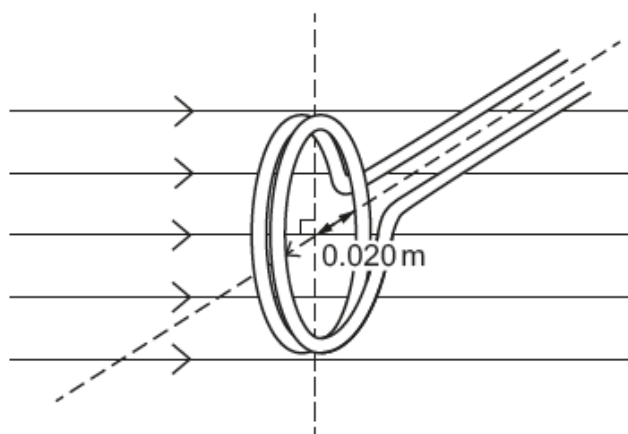

(a) (i) The coil has 10 turns of radius 0.020 m. The field strength is 5.0 mT.

Show that the flux linkage of the coil is about  $6.3 \times 10^{-5}$  Wb.

[2]

Most candidates were able to calculate the flux linkage, but as this was a 'show that' question they needed to write down the equation and show the working to find the area of the coil from the radius.



Question 4 (a) (ii)

The coil is rotated at a constant rate as shown in Fig. 4.2. An emf is produced across the coil.

Fig. 4.2

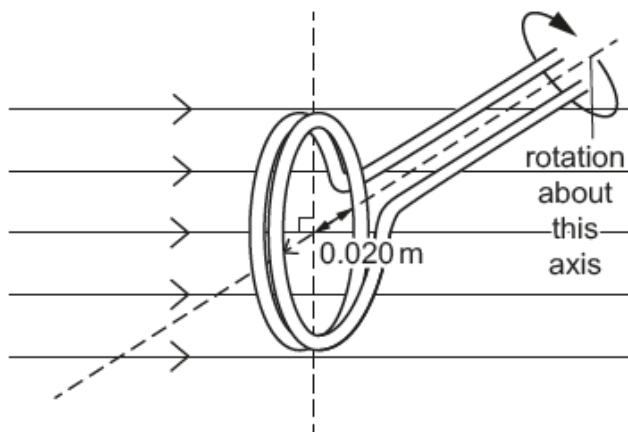

An oscilloscope trace of the emf produced is shown in Fig. 4.3.

Fig. 4.3

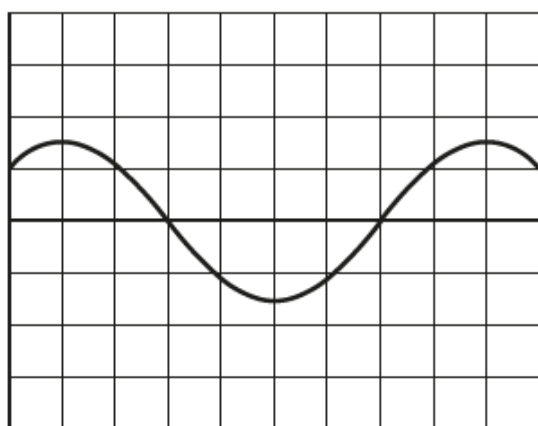

(ii) Suggest and explain why the trace has the shape shown on Fig. 4.3.

.....

.....

.....

.....

.....

..... [2]

Candidates found it difficult to explain the concept of electromagnetic induction, and only a few candidates were able to explain clearly. Some candidates did gain some credit for stating Faraday's Law but then didn't manage to separate the idea of maximum change of flux as opposed to the maximum flux.

Exemplar 2

EMF varies sinusoidally with time. EMF is proportional to the rate of flux cutting. The flux varies sinusoidally with time and therefore the EMF does as well.

This candidate has correctly stated that emf is proportional to the rate of flux cutting. Then the second sentence is not quite correct as it is actually the area cutting the constant flux, which is varying sinusoidally, not the flux itself.

Question 4 (a) (iii)

- (iii) The horizontal divisions on the trace representing time are set at 0.625 s/div. Using the trace shown in Fig. 4.3, calculate the angular frequency,  $\omega$ , of the coil.

Angular frequency,  $\omega = \dots\dots\dots \text{rads}^{-1}$  [3]

Most candidates were able to correctly calculate the angular frequency. The most common error was to use ten squares instead of eight for the period of the oscillation.

## Question 4 (a) (iv)

- (iv) The angle  $\theta$ , that the normal to the plane of the coil makes with the field lines varies with time as the coil rotates. Angle  $\theta$  is shown in **Fig. 4.4**.

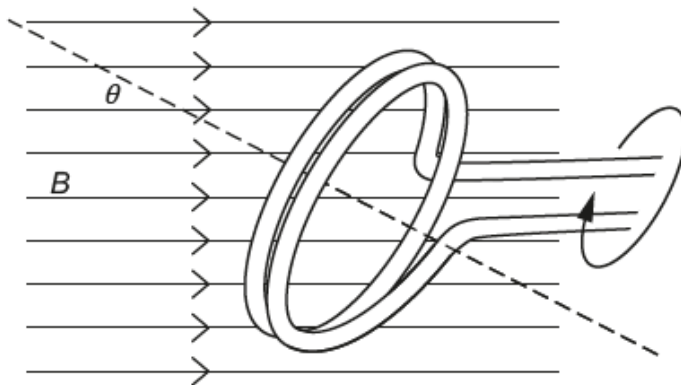
**Fig. 4.4**

By considering  $\theta$ , show that the flux in the coil can be given by  $\phi = BA \cos \omega t$ .

**[2]**

Answers seemed to split into two groups: the ones from those candidates who knew what they were talking about, and those which started from  $\phi = BA \cos \omega t$  and eventually stumbled back to where they had started. There was also some confusion between  $\phi$  and  $\theta$ .

## Question 4 (b) (i)

(b) The original trace of the coil is shown in Fig. 4.5.

Fig. 4.5

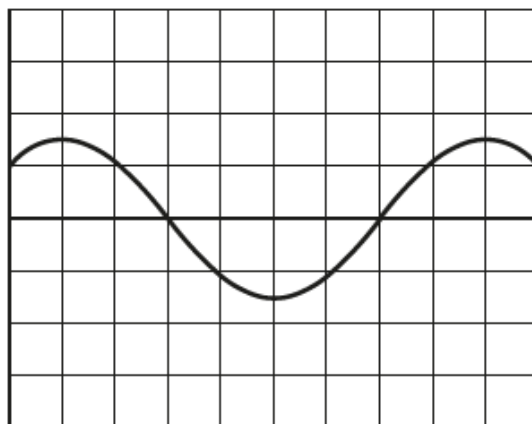

The number of turns of the coil is changed to 20. Nothing else is changed.

(i) Add to Fig. 4.5 a drawing of the trace produced by the 20-turn coil.

[2]

Many candidates got the correct amplitude and period, but some found it difficult because the edge of the grid was not at the maximum or equilibrium position.

Question 4 (b) (ii)

The driving force spinning the coil is removed. Fig. 4.6 shows how the flux linkage varies with time for three whole revolutions.

Fig. 4.6

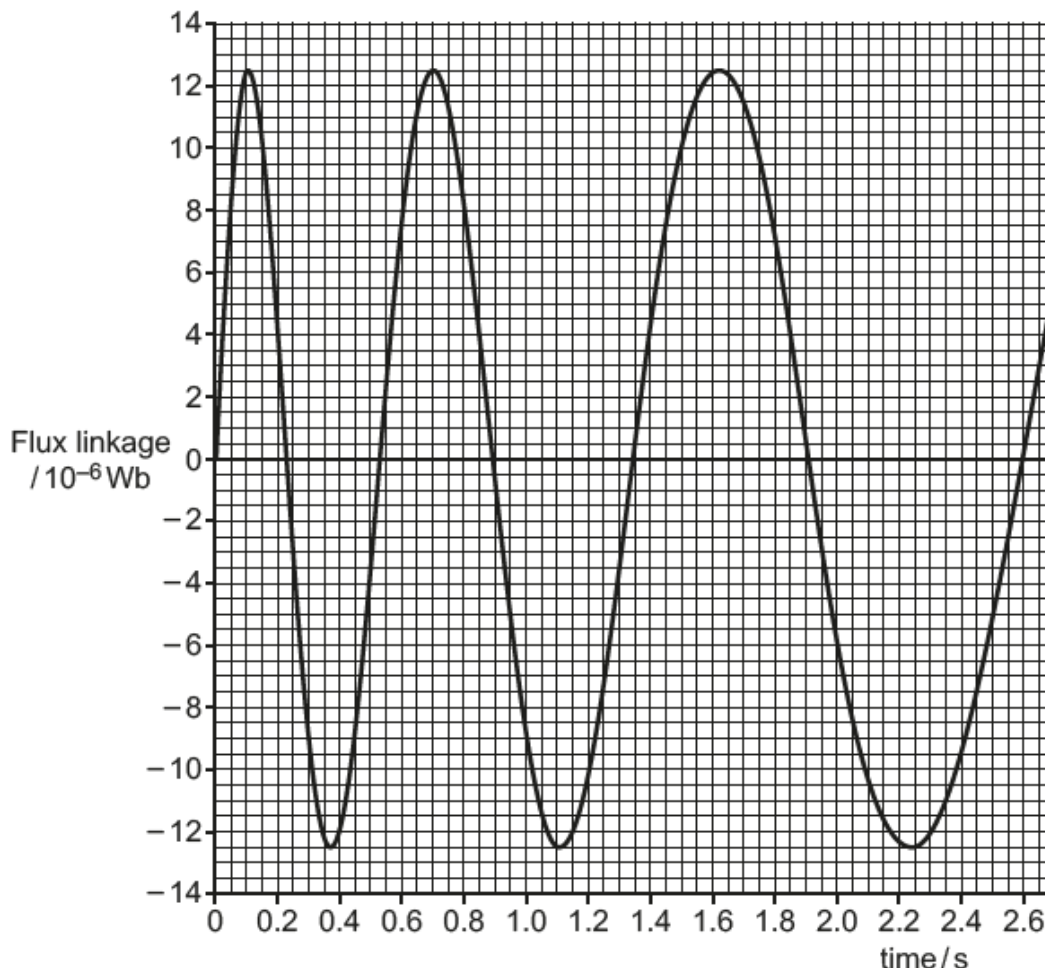

- (ii) Using the graph in Fig. 4.6, estimate the emf induced in the coil at the instant the flux linkage is zero at 0.23s. Show all your working.

emf = ..... V [3]

Most candidates answered this question well. Of those who lost marks, a significant number multiplied their gradients by 20. Other common errors were to lose the  $\times 10^{-6}$  factor, leading to answers of the order of 140 V; drawing tangent lines which were too steep, so that the final answer fell outside the acceptable range; and dividing 12.5 by 0.23.

### Question 4 b (iii)\*

- (iii)\* It is suggested that the peak emf generated by the coil falls by the same fraction in each cycle.

Explain how this suggestion can be tested by using data from **Fig. 4.6**.

Carry out your test on the data and state your conclusions.

.....

.....

.....

.....

.....

.....

.....

..... [6]

There were many competent responses given for this question. Several carried out appropriate tests, as indicated with their working, but did not explain the method clearly. The vast majority calculated the emfs from the tangents, presumably prompted by the previous part of the question; few compared the periods; few candidates used the formula approach. Some candidates confused the issue by finding the gradient at 0.53 and 1.35 s and comparing these with the value for 0.23 s. A few suggested, e.g. "finding the induced emf at the maximum and minimum points" without realising that they would be zero.

Exemplar 3

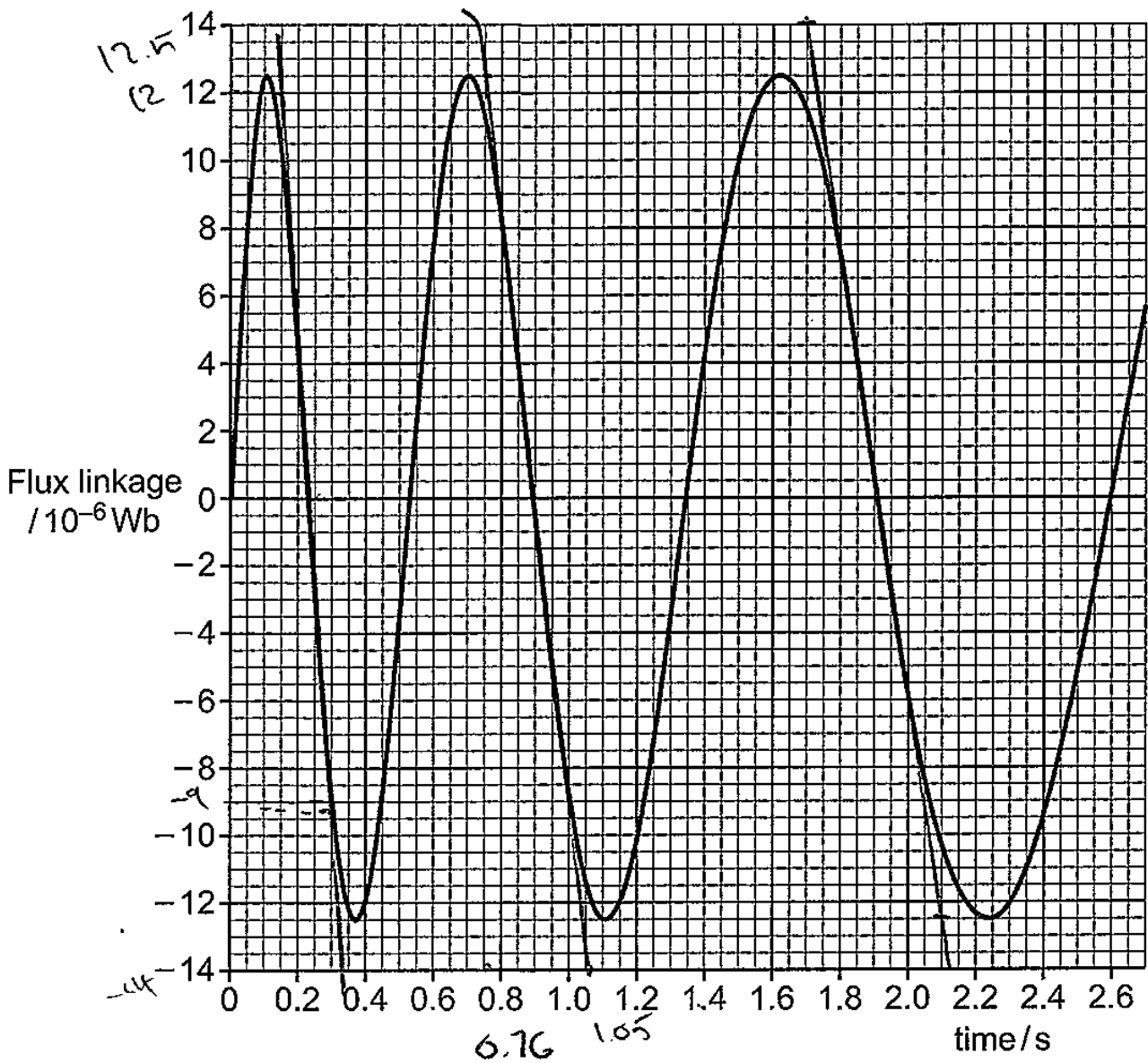

This could be tested by measuring the emf when the flux linkage is both falling ~~or~~ <sup>falling</sup> increasing and is 0. Then by measuring the this is done by measuring the gradient at those points. If the emf falls by the same fraction each time we shall see it using this method

emf at  $t_c = 1.2 \times 10^{-4} \text{ V}$

$$\text{emf at } t=0 = \frac{\Delta \psi}{\Delta t} = \frac{(12.5 - 14) \times 10^{-6}}{1.05 \times 0.76} = 3.32 \times 10^{-5}$$

$$\text{emf at } t=1.85 = \frac{\Delta \psi}{\Delta t} = \frac{(14 - 12.5) \times 10^{-6}}{11.7 - 2.11} = 6.625 \times 10^{-5}$$

$$\text{emf at } t=2 = \frac{6.625 \times 10^{-5}}{3.32 \times 10^{-5}} = 1.995$$

$$\frac{3.32 \times 10^{-5}}{1.2 \times 10^{-4}} = 0.277$$

We can assume it does not decrease by the same amount each cycle. [6]

This candidate has explained how to test the suggestion by finding the gradient when the flux linkage is zero and has shown the gradient lines on Fig. 4.6. Then some calculations are shown but their second value of emf is incorrect as there is a multiplication sign on the denominator. The candidate has then found two ratios of successive max emf and has drawn a conclusion. This method would have worked had the calculations been correct, so this is a Level 2 response.



---

# Supporting you

---

## Teach Cambridge

Make sure you visit our secure website [Teach Cambridge](#) to find the full range of resources and support for the subjects you teach. This includes secure materials such as set assignments and exemplars, online and on-demand training.

**Don't have access?** If your school or college teaches any OCR qualifications, please contact your exams officer. You can [forward them this link](#) to help get you started.

## Reviews of marking

If any of your students' results are not as expected, you may wish to consider one of our post-results services. For full information about the options available visit the [OCR website](#).

## Access to Scripts

For the June 2023 series, Exams Officers will be able to download copies of your candidates' completed papers or 'scripts' for all of our General Qualifications including Entry Level, GCSE and AS/A Level. Your centre can use these scripts to decide whether to request a review of marking and to support teaching and learning.

Our free, on-demand service, Access to Scripts is available via our single sign-on service, My Cambridge. Step-by-step instructions are on our [website](#).

## Keep up-to-date

We send a monthly bulletin to tell you about important updates. You can also sign up for your subject specific updates. If you haven't already, [sign up here](#).

## OCR Professional Development

Attend one of our popular CPD courses to hear directly from a senior assessor or drop in to a Q&A session. Most of our courses are delivered live via an online platform, so you can attend from any location.

Please find details for all our courses for your subject on **Teach Cambridge**. You'll also find links to our online courses on NEA marking and support.

## Signed up for ExamBuilder?

**ExamBuilder** is the question builder platform for a range of our GCSE, A Level, Cambridge Nationals and Cambridge Technicals qualifications. [Find out more](#).

ExamBuilder is **free for all OCR centres** with an Interchange account and gives you unlimited users per centre. We need an [Interchange](#) username to validate the identity of your centre's first user account for ExamBuilder.

If you do not have an Interchange account please contact your centre administrator (usually the Exams Officer) to request a username, or nominate an existing Interchange user in your department.

## Active Results

Review students' exam performance with our free online results analysis tool. It is available for all GCSEs, AS and A Levels and Cambridge Nationals.

[Find out more](#).

## Need to get in touch?

If you ever have any questions about OCR qualifications or services (including administration, logistics and teaching) please feel free to get in touch with our customer support centre.

Call us on  
**01223 553998**

Alternatively, you can email us on  
**support@ocr.org.uk**

For more information visit

 **ocr.org.uk/qualifications/resource-finder**

 **ocr.org.uk**

 **facebook.com/ocrexams**

 **twitter.com/ocrexams**

 **instagram.com/ocrexaminations**

 **linkedin.com/company/ocr**

 **youtube.com/ocrexams**

## We really value your feedback

Click to send us an autogenerated email about this resource. Add comments if you want to. Let us know how we can improve this resource or what else you need. Your email address will not be used or shared for any marketing purposes.



**I like this**



**I dislike this**

Please note – web links are correct at date of publication but other websites may change over time. If you have any problems with a link you may want to navigate to that organisation's website for a direct search.



OCR is part of Cambridge University Press & Assessment, a department of the University of Cambridge.

For staff training purposes and as part of our quality assurance programme your call may be recorded or monitored. © OCR 2023 Oxford Cambridge and RSA Examinations is a Company Limited by Guarantee. Registered in England. Registered office The Triangle Building, Shaftesbury Road, Cambridge, CB2 8EA. Registered company number 3484466. OCR is an exempt charity.

OCR operates academic and vocational qualifications regulated by Ofqual, Qualifications Wales and CCEA as listed in their qualifications registers including A Levels, GCSEs, Cambridge Technicals and Cambridge Nationals.

OCR provides resources to help you deliver our qualifications. These resources do not represent any particular teaching method we expect you to use. We update our resources regularly and aim to make sure content is accurate but please check the OCR website so that you have the most up to date version. OCR cannot be held responsible for any errors or omissions in these resources.

Though we make every effort to check our resources, there may be contradictions between published support and the specification, so it is important that you always use information in the latest specification. We indicate any specification changes within the document itself, change the version number and provide a summary of the changes. If you do notice a discrepancy between the specification and a resource, please [contact us](#).

You can copy and distribute this resource freely if you keep the OCR logo and this small print intact and you acknowledge OCR as the originator of the resource.

OCR acknowledges the use of the following content: N/A

Whether you already offer OCR qualifications, are new to OCR or are thinking about switching, you can request more information using our [Expression of Interest form](#).

Please [get in touch](#) if you want to discuss the accessibility of resources we offer to support you in delivering our qualifications.